

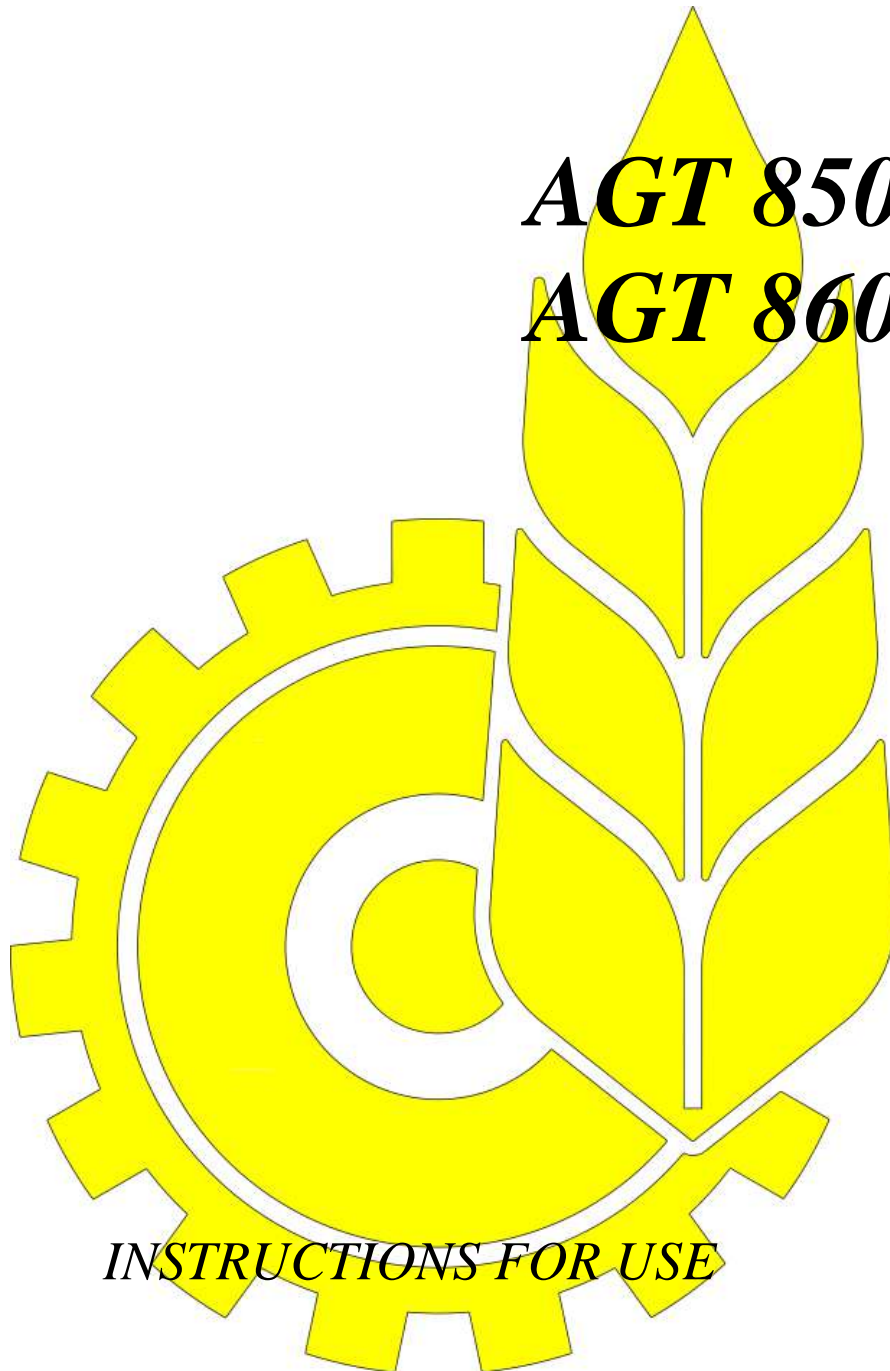

Agromehnika

AGT 850

AGT 860



INSTRUCTIONS FOR USE

INDEX

EC DECLARATION OF CONFORMITY.....	2
1 GENERAL.....	3
2 SAFETY	4
2.1 SAFETY SIGNS	4
2.2 DEFINITIONS.....	4
2.3 SAFETY WARNINGS.....	5
2.4 USER OR CUSTOMER	6
2.4.1 PREPAREDNESS FOR DANGERS	7
2.4.2 PERSONAL PROTECTION	7
2.5 SAFETY INSTRUCTIONS BEFORE USING THE TRACTOR.....	8
2.5.1 ENTERING THE TRACTOR	8
2.6 SAFETY INSTRUCTIONS DURING TRACTOR USE	9
2.6.1 DANGER AREA	9
2.6.2 STANDARD SAFETY EQUIPMENT	9
2.6.3 STARTING THE TRACTOR UNDER SAFE CONDITIONS	11
2.6.4 STOPPING THE TRACTOR UNDER SAFE CONDITIONS.....	12
2.6.5 WORKING WITH TRACTOR	12
2.6.6 USING THE TRACTOR WITH INSTALLED WEIGHTS	13
2.7 SAFETY INSTRUCTIONS AFTER USING THE TRACTOR.....	13
2.8 USING THE TRACTOR ON SLOPES	13
2.9 USING IMPLEMENTS	14
2.9.1 CARRIED IMPLEMENTS	15
2.9.2 TOWED IMPLEMENTS	15
2.9.3 CARDAN SHAFT	15
2.10 USING THE TRACTOR ON THE ROAD	16
2.11 TRANSPORT OF TRACTOR	17
2.11.1 TRANSPORT	17
2.11.2 TOWING	17
2.12 MAINTENANCE.....	18
2.12.1 HYDRAULIC SYSTEM.....	18
2.12.2 BODYWORK	19
2.12.3 WHEELS	19
2.12.4 COOLING SYSTEM.....	19
2.12.5 ELECTRICAL SYSTEM.....	20
2.12.6 ENVIRONMENT PROTECTION (RECYCLING).....	21
2.12.7 NOISE.....	21
2.13 USING THE TRACTOR FOR SPRAYING	22
2.14 USING THE TRACTOR IN FORESTRY	22
2.15 FRONT LOADER	23
2.16 ADDITIONAL SAFETY REQUIREMENTS	23
2.17 SAFETY SIGNS ON THE TRACTOR	24
2.17.1 MEANING AND POSITION OF SAFETY SIGNS	25

3	TECHNICAL SPECIFICATION	26
3.1	MANUFACTURER'S INFORMATION.....	26
3.2	REPLACEMENT PARTS	27
4	GENERAL DESCRIPTION OF TRACTOR	28
4.1	DESCRIPTION OF TRACTOR'S MAIN COMPONENTS	29
4.2	DESCRIPTION OF MAIN SAFETY COMPONENTS.....	31
4.2.1	CABIN.....	31
4.2.2	ROLL BAR.....	34
4.2.3	SAFETY BELT	35
4.2.4	PROTECTIVE COVER OF CARDAN DRIVE.....	35
4.3	DRIVER'S SEAT.....	36
4.3.1	ACCESS TO DRIVER'S SEAT	36
4.3.2	DRIVER'S SEAT.....	36
4.4	DESCRIPTION OF HYDRAULICS	37
4.4.1	HYDRAULIC SCHEME.....	38
4.4.2	FRONT HYDRAULIC LIFT SYSTEM (OPTION).....	40
4.4.3	REAR HYDRAULIC LIFT MECHANISM.....	41
4.5	DESCRIPTION OF INSTRUMENTS AND CONTROL ELEMENTS	43
4.5.1	DASHBOARD.....	43
4.5.2	DESCRIPTION OF CONTROL ELEMENTS (CABIN)	48
4.5.3	DESCRIPTION OF CONTROL ELEMENTS FOR DRIVING (PEDALS)	50
4.5.4	DESCRIPTION OF CONTROL ELEMENTS FOR WORK (CONNECTION SHAFT)	52
4.5.5	DESCRIPTION OF CONTROL ELEMENTS FOR HYDRAULICS.....	53
4.6	OPTIONAL EQUIPMENT	57
4.6.1	REAR LIFT MECHANISM	57
4.6.2	FRONT LIFT MECHANISM.....	59
4.6.3	FRONT HYDRAULIC CONNECTION	59
4.6.4	WHEEL DIMENSIONS	60
4.6.5	WHEEL EXTENSIONS	60
4.6.6	WEIGHTS	60
4.6.7	ROTATION LIGHT	61
4.6.8	FLOATING HYDRAULICS WITH SUPPORT	61
4.6.9	HYDRAULIC BRAKE OF TOWED IMPLEMENT.....	63
4.7	PREMIUM HYDRAULICS (OPTION)	66
4.7.1	HYDRAULIC SCHEME.....	66
4.7.2	DESCRIPTION OF CONTROL ELEMENTS FOR HYDRAULICS.....	69
4.7.3	CONTROL VALVES.....	69
4.7.4	POSITIONING OF CONTROL VALVES.....	70
4.7.5	FUNCTIONING OF CONTROL ELEMENTS FOR HYDRAULICS	71
4.7.6	CONNECTION SHAFT OPERATION	75
4.7.7	OPERATION OF HYDRAULIC LIFT MECHANISM.....	75
4.7.8	OPERATION OF 3-DIRECTIONAL VALVE	77
4.7.9	CHOKE OF REAR HYDRAULIC CYLINDERS	77
4.8	PREMIUM PLUS HYDRAULICS	78
4.8.1	HYDRAULIC SCHEME.....	78
4.8.2	OPERATION OF FLOATING SYSTEM	80
4.8.3	CONTROL BLOCK OF HYDRAULIC SYSTEM	81
4.8.4	TABLE OF IMPLEMENT SUPPORT FORCE	81
4.9	DESCRIPTION OF DEVICES FOR USING THE TRACTOR IN ROAD TRAFFIC	82

4.10	ELECTRICAL SYSTEM.....	82
4.10.1	BATTERY	82
4.10.2	ELECTRIC STARTER.....	83
4.10.3	ALTERNATOR	83
4.10.4	FUSES.....	83
4.10.5	SOCKET FOR CONNECTIONS (ISO 1724)	84
5	TRACTOR TRANSPORT.....	85
5.1	LOADING.....	85
5.2	UNLOADING	86
5.3	TOWING.....	86
6	TRACTOR SETTINGS.....	88
6.1	SEAT AND STEERING WHEEL	88
6.1.1	SEAT SETTINGS.....	88
6.1.2	STEERING WHEEL SETTING.....	91
6.2	LIGHTING SETTINGS.....	91
6.2.1	SETTING HEADLIGHTS.....	91
6.2.2	SETTING TOP (WORK) LIGHTS (WITH INSTALLED CABIN).....	93
6.3	SETTING REAR HYDRAULIC LIFT MECHANISM.....	93
6.3.1	SETTING OF LOWER CONNECTION ARMS.....	94
6.3.2	SETTING OF LIFT BAR	95
6.3.3	SETTING OF TOP CONNECTION BAR (TOP LINK).....	96
6.3.4	SETTING OF LATERAL TENSIONER.....	97
6.4	SETTING OF FRONT HYDRAULIC LIFT MECHANISM (OPTION).....	97
6.4.1	SETTING OF LOWER CONNECTION ARMS.....	97
6.5	SETTING OF REAR TOWING HOOK.....	98
6.6	SETTING OF CLUTCH PEDAL	99
7	USING THE TRACTOR	99
7.1	USING THE ROLL BAR	99
7.2	TRACTOR COVER.....	100
7.3	USING TRACTOR HYDRAULICS.....	101
7.3.1	OPERATION OF LIFT MECHANISM	101
7.3.2	USING REAR HYDRAULIC LIFT MECHANISM.....	101
7.3.3	USING FRONT HYDRAULIC LIFT MECHANISM	102
7.4	TRACTOR START-UP	102
7.4.1	TRACTOR START-UP.....	103
7.4.2	TRACTOR SHUTDOWN	103
7.4.3	TRACTOR START-UP WITH BATTERY AID.....	104
7.5	STARTING CONNECTION SHAFT (PTO).....	105
7.5.1	STARTING CONNECTION SHAFT	105
7.5.2	CONNECTION SHAFT ROTATION IN REGARD TO OPERATION MODE.....	105
7.5.3	CONNECTION SHAFT SHUTDOWN	105
7.5.4	START-UP CHOKE (SOFT START – PTO).....	106
7.6	PREPARATION OF TRACTOR FOR ROAD	106
7.6.1	DRIVING THE TRACTOR	107
7.6.2	STOPPING THE TRACTOR	107

7.7	IMPLEMENT	108
7.7.1	CONNECTION AND DISCONNECTION OF IMPLEMENT ON REAR HYDRAULIC LIFT MECHANISM	108
7.7.2	CONNECTION AND DISCONNECTION OF IMPLEMENT ON FRONT HYDRAULIC LIFT MECHANISM	111
7.7.3	CONNECTION AND DISCONNECTION OF IMPLEMENT ON REAR TOWING HOOK.....	112
7.8	CARDAN SHAFT (NOT DELIVERED)	113
7.8.1	CONNECTION AND DISCONNECTION OF CARDAN SHAFT	113
7.9	CONNECTION OF TRACTOR	115
7.9.1	CONNECTION OF HYDRAULIC COUPLINGS	115
7.9.2	ELECTRICAL CONNECTION	116
7.10	INSTALLING WEIGHTS AND EXTENSIONS	116
7.10.1	INSTALLATION OF 40 KG WHEEL WEIGHTS	116
7.10.2	INSTALLATION OF 50 KG WHEEL WEIGHTS	117
7.10.3	INSTALLATION OF 340 KG REAR WEIGHT	118
7.10.4	INSTALLATION OF WHEEL EXTENSIONS	118
7.11	LONGER STANDSTILL AND RESTART	119
7.11.1	LONGER TRACTOR STANDSTILL.....	119
7.11.2	RESTARTING THE TRACTOR.....	120
7.12	FILLING THE TANK	120
8	TRACTOR MAINTENANCE	121
8.1	WHEELS	121
8.1.1	TRACTOR LIFT POINTS.....	121
8.1.2	INSTALLATION OF WHEELS	122
8.1.3	TYRES	123
8.1.4	REST OF WHEEL END POSITION	123
8.1.5	TRACK SETTING	124
8.2	ELECTRICITY	124
8.2.1	REPLACING THE BATTERY	124
8.2.2	CHANGING BULBS	125
8.3	MAINTENANCE TABLE	127
8.4	CLEANING THE TRACTOR	129
8.5	ENGINE MAINTENANCE	129
8.5.1	CHECKING ENGINE OIL LEVEL	129
8.5.2	CHANGING ENGINE OIL	130
8.5.3	CHANGING OIL FILTER	130
8.5.4	CHANGING AIR FILTER	131
8.5.5	CLEANING AIR FILTER	131
8.5.6	CHANGING FUEL FILTER	132
8.5.7	CHECKING/CHANGING BELT.....	133
8.6	MAINTENANCE OF COOLING SYSTEM	134
8.6.1	CHECKING COOLING LIQUID LEVEL.....	134
8.6.2	DISCHARGE AND ADDING COOLING LIQUID	134
8.6.3	CLEANING RADIATOR GRILL	134
8.6.4	CLEANING THE RADIATOR WITH CLEANFIX SYSTEM (OPTION)	135
8.7	CHECKING WHEELS	136
8.7.1	CHECKING TYRE PRESSURE.....	136

8.8	MAINTENANCE OF TRANSMISSION	137
8.8.1	CHECKING OIL IN GEARBOX	137
8.8.2	CHANGING OIL IN GEARBOX	137
8.8.3	CHANGING OIL FILTER OF HYDRAULIC SYSTEM	138
8.8.4	CHECKING OIL IN FRONT DIFFERENTIAL	139
8.8.5	CHANGING OIL IN FRONT DIFFERENTIAL	139
8.8.6	CHECKING OR CHANGING OIL IN LATERAL REDUCERS	140
8.9	MAINTENANCE OF AIR CONDITIONING	141
8.9.1	CHARGING AIR CONDITIONING	142
8.10	LUBRICATION POINTS ON TRACTOR	142
8.10.1	SCHEME OF LUBRICATION POINTS	142
9	TRACTOR OPERATION TROUBLESHOOTING	144
10	TECHNICAL DATA	150
10.1	TRACTOR DIMENSIONS	150
10.1.1	REAR LIFT MECHANISM DIMENSIONS	151
10.1.2	FRONT LIFT MECHANISM DIMENSIONS	152
10.1.3	REAR TOWING HOOK HEIGHT	153
10.1.4	TRACTOR AXLE LENGTHS	154
10.2	TYRES	155
10.2.1	TYRE WIDTH	155
10.2.2	TYRE PRESSURE	155
10.3	TRACTOR WEIGHT	156
10.3.1	MAXIMUM TECHNICALLY ALLOWED TRACTOR WEIGHT	156
10.3.2	MAXIMUM LOAD ON AXLES AND IN CONNECTION POINT	156
10.3.3	MAXIMUM TENSILE LOAD OF CONNECTION POINT	157
10.4	WEIGHTS	157
10.5	NOISE LEVEL	158
10.5.1	DRIVER VIBRATIONS	158
10.6	INCLINATION	158
10.7	TECHNICAL CHARACTERISTICS	159
10.7.1	OILS	160
10.7.2	COOLING LIQUID	160
10.7.3	LUBRICANTS	160
10.8	CONNECTION SHAFT	161
10.8.2	CONNECTION SHAFT PROPERTIES	161
10.8.3	CONNECTION SHAFT SPEED TABLE	161
10.9	SCHEME OF GEARBOX GEARS	164
10.9.2	TRACTOR SPEED	166
10.10	ELECTRICAL CONNECTION OF TRACTOR	169
10.10.2	LEGEND	169
10.10.3	CONNECTION SCHEME OF MAIN SUPPLY (IGNITION – START-UP OF ENGINE)	170
10.10.4	CONNECTION SCHEME OF DASHBOARD	171
10.10.5	CONNECTION SCHEME FOR HEADLIGHTS, LATERAL LIGHTS AND SOUND WARNING	172
10.10.5	CONNECTION SCHEME FOR INDICATOR LIGHTS, REAR LIGHT AND CONNECTION TO TRAILER	173
10.10.6	CONNECTION SCHEME FOR DIFFERENTIAL LOCK AND CARDAN SHAFT	174
10.10.7	DESCRIPTION OF ELEMENT FUNCTIONS	175
10.11	RECALCULATIONS OF TRACTOR LOAD	177

We thank you for your trust in choosing our tractor series AGT 850.

After many years of experience, we can say that we, based on international guidelines for developing such tractors and on observations of desires and demands of customers, have developed a product of high standards in regard to highest quality between performance and reliability in use in different fields of agriculture, municipal services and simpler production.



TRACTOR AGT 850

EC DECLARATION OF CONFORMITY

Manufacturer:

**AGROMEHANIKA, proizvodnja in trgovina Kranj d.d.
Hrastje 52 a, KRANJ, SLOVENIA**

declares that the product:

Tractor AGT 850

is produced in accordance with:

- 1. Machinery Directive 2006/42/EC;**
- 2. Directive on type-approval of agricultural and forestry tractors on wheels 2003/37/EC;**
- 3. Rules on acquiring certificate on conformity of agricultural and forestry tractors according to guidelines of technical specifications (TSV). (Uradni list RS, No. 1/12)**

The following harmonized European standards on safety were complied with:

SIST EN ISO 4254-1:2010 – Agricultural machinery – Safety – Part 1: General requirements (ISO 4254-1:2008);

SIST EN ISO 4254-1:2010/AC:2011 – Correction AC:2011 to standard SIST EN ISO 4254-1:2010;

SIST EN ISO 5674:2009 – Tractors and agricultural and forestry machinery – Shields for connection shafts – Tests of strength and wear and admissibility criteria (ISO 5674:2004);

SIST EN ISO 12100:2011 – Machine safety – General principles of planning – Risk assessment and risk reduction (ISO 12100:2010);

SIST EN ISO 13857:2008 – Machine safety – Safety distances to prevent reaching into dangerous areas with upper and lower limbs.

Kranj, 26.4.2013

Production manager:
(responsible for tech.
documentation)

Matjaž Kuhar, B.Eng.



Manager:

Jan Šinkovec



1 GENERAL

AGT tractors are designed and produced to provide users with the best reliability and work performance. However, a lot depends on the user, his approach to work and subsequent maintenance and proper care of the tractor.

Carefully read instructions for safe use and maintenance and heed to them when handling the tractor to perform them correctly as the user of your new AGT tractor.

Instructions for use and maintenance are a component part of the tractor and contain vital information for efficient and safe use and long life expectancy of the tractor.

Keep instructions for use and maintenance in an easy accessible place, so that they are available in any situation.

Enclose the instructions upon possible sale of the tractor to another purchaser.

If you require expert assistance, contact our service centres, where we will gladly provide support. Upon contact, provide exact information about your tractor, provided on the identification plate.



When purchasing AGT tractor, you receive documentation, which, along with instructions for use, includes instructions for use and maintenance of the engine, warranty and CE declaration of conformity of the product.

NOTE



Due to development and modifications, minor deviances of the text of Instructions for use and maintenance can occur from the actual state of the tractor. Therefore, we, as the manufacturer, reserve the right to technical changes of information without prior notification of the customer.

2 SAFETY

2.1 SAFETY SIGNS

There are three main types of safety signs for danger, warning and important, which can be found in the instructions and tractor decals. Whenever you see such a sign, heed to their content of instructions for safe work, and act accordingly in special situations. Consequences of not heeding to safety warnings for danger can be serious injuries or even death.

Heed to these safety regulations for your own safety!

	<p>IMPORTANT: This symbol represents important technical information regarding different work procedures and warns about potential danger, which can arise during operation and can have lighter injury as consequence.</p>
	<p>WARNING: This symbol warns about potential danger, which can arise and can have serious injury to the operator or damage to the tractor and its equipment as consequence.</p>
	<p>DANGER: This symbol warns about immediate danger, which can have serious injury or even death as consequence.</p>

2.2 DEFINITIONS

Definitions, explained in the following, explain use of certain terms, which come up in the Instructions for use.

- **FOPS (Falling objects protective structure)**, safety structure, which protects the driver in case of falling objects from above;
- **OPS (Operator protective structure)**, safety structure, which protects the driver in case of object protrusion;
- **ROPS (Roll over protective structure)**, safety arch or safety cabin, which protects the driver in case of tractor rolling over;
- **USER**, person trained and properly educated for work with the tractor and authorized for its servicing;
- **MAINTENANCE**, a series of service operations, which enable functionality and effective tractor operation for further use. Maintenance procedure is normally defined by the manufacturer in corresponding intervals and execution procedures;
- **DANGEROUS AREA**, area, where great danger of safety and health hazard of persons exists.

- **VIEWING DIRECTION**, tractor position is determined according to drawing and is conditioned by driving direction. Directions, shown in the figure, are used in the Instructions for use.

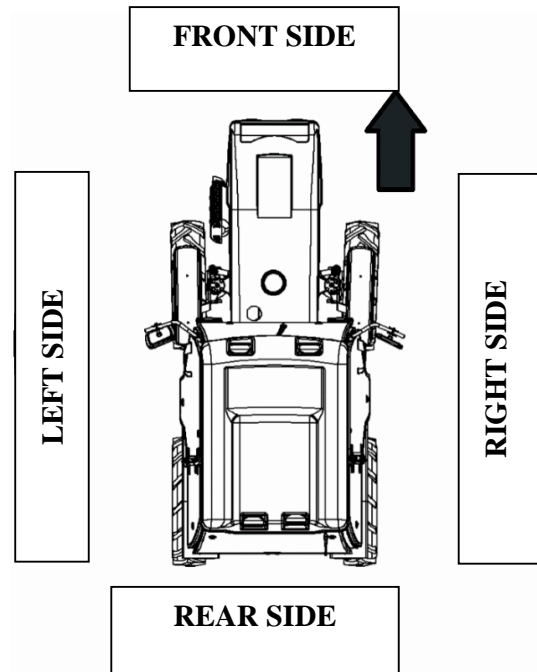

2.3 SAFETY WARNINGS

- Carefully read instructions regarding safety regulations in the instructions for use of your tractor.
- Familiarize yourself with tractor operation and handling and its control units.
- Familiarize yourself in detail with tractor properties, such as weight, load capacity (load), speed, tractor stability etc., so there is no consequences due to disregard in terms of serious injury.
- Always act according to regulations, especially when driving on public roads.
- Ensure that the signs on the tractor are clearly visible.
- Never remove or paint safety signs on the tractor.
- After repair and replacement of component part on the tractor, make sure that it includes all required safety signs. Safety signs are available at authorized dealers.
- Ensure that your tractor is in good technical state. Each unauthorized modification on the tractor can reduce its function, as well as safe operation, and can shorten its life expectancy.



2.4 USER OR CUSTOMER

Before commencing work, user must be previously informed about the tractor and its correct use of all working functions, especially in certain parts, where extreme caution is required. Therefore, it is recommended that:

- The user is familiar with the instructions for use before using the tractor and confirms that he will follow all safety instructions for work and maintenance consistently;
- The user is familiar with safety warnings in the instructions for use and safety decals on the tractor;
- The user ensures correct maintenance and checks of the tractor and its parts;
- The user, upon damage or malfunction, ensures replacement of parts with original ones, otherwise the manufacturer can nullify warranty free from liabilities;
- Other persons (third persons), who do not possess required knowledge, familiarize themselves with the instructions for use;
- The user, when being the employer, instructs the person in charge of work on the tractor or organizes education for this person;
- The user does not allow persons without adequate knowledge to operate the tractor;
- The tractor is operated by only one person, without an assistant, except in case of driving with objects, which obstruct the view and prevent good overview of the driver's field of view. The assistant is in charge only of showing correct driving direction:
 - must not ride on the tractor;
 - must heed to safety distance during work.
- The user is healthy – mentally and physically;
- The user of the tractor is medically examined (in accordance with local regulations).



WARNING: Never use the tractor under the influence of alcohol or other substances. In case of using medication, consult your physician beforehand.



WARNING: Do not allow unauthorized persons or persons under the age of 18 to operate the tractor.

2.4.1 PREPAREDNESS FOR DANGERS

- Be prepared for sudden fire.
- Make sure that, during work, there are always a first aid kit and a fire extinguisher present.
- Make sure that you have phone numbers of your physician, emergency, doctor's office, hospital and fire service present in a visible place.

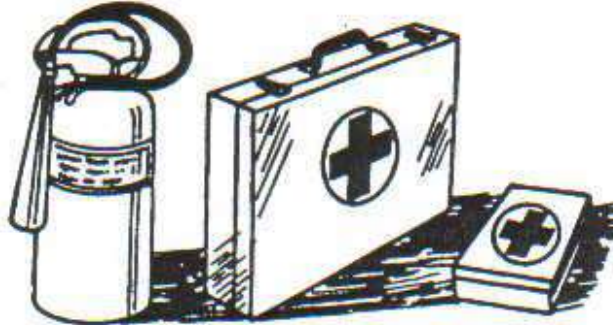

2.4.2 PERSONAL PROTECTION

During work, the tractor operator must wear well fitting clothing and effective protection equipment:



- Protective helmet
- Face protection (goggles or mask)
- Protective gloves
- Suitable work clothing (not loose)
- Appropriate hearing protection means
- Protective footwear



If, during work with the tractor, you are in contact with pesticides, use suitable means of personal protection provided above (protective mask, work clothing...) in accordance with recommendations of pesticide manufacturer.

2.5 SAFETY INSTRUCTIONS BEFORE USING THE TRACTOR

Use the tractor only with original parts and safety devices, installed by the manufacturer.

- Perform a visual inspection of the tractor, make sure that all of the parts and equipment are installed properly and/or are not damaged:
 - Check proper functioning of brakes, including handbrake;
 - Check functioning of hydrostatic control system;
 - Check oil level and add, if required;
 - Check the state of electrical system (battery, wires, headlights, warning lights...).
- Before use, perform a visual inspection of tractor tyres:
 - Check pressure. If the tyre has insufficient pressure, inflate it;
 - Check for possible damages, such as protrusions or cuts;
 - Check tyre tread wear.
- Never overinflate tyres, because they can explode!

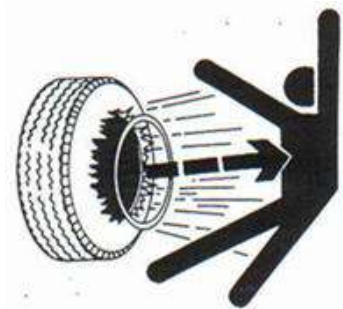

WARNING: If there are signs of wear or damage, immediately replace the tyre!

2.5.1 ENTERING THE TRACTOR

- Entering the tractor is possible from both of its sides.
- Never enter the tractor elsewhere as arranged, as serious injury can occur in case of fall.
- Before entering the tractor, make sure that the surfaces and steps are clean, free of mud, oil, dust etc. In winter time, always remove any ice or snow before entering.
- When entering the tractor, use the handrail and step. Never grab shift lever and do not step on the pedal when entering.
- Always use "three-point grip" – both legs and one arm or one leg, both arms – when getting into or out of the machine.

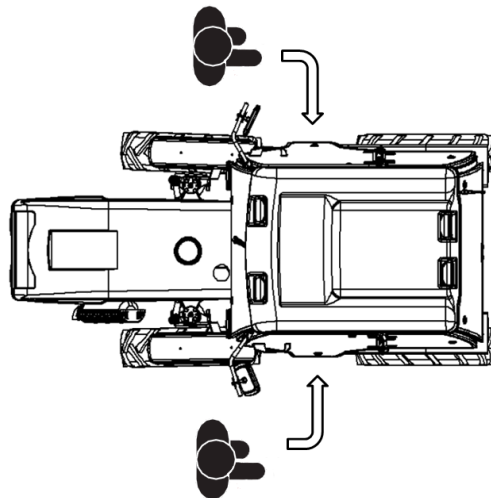

WARNING: During driving, do not get out of the tractor or vice versa!

2.6 SAFETY INSTRUCTIONS DURING TRACTOR USE

Use the tractor for work in accordance with regulations and strictly follow safety instructions.

2.6.1 DANGER AREA

- Before commencing work, make sure that other persons, especially elderly and children, are out of the tractor's danger area, especially when it is working or in motion. If required, stop the tractor and move the persons to a safe distance.

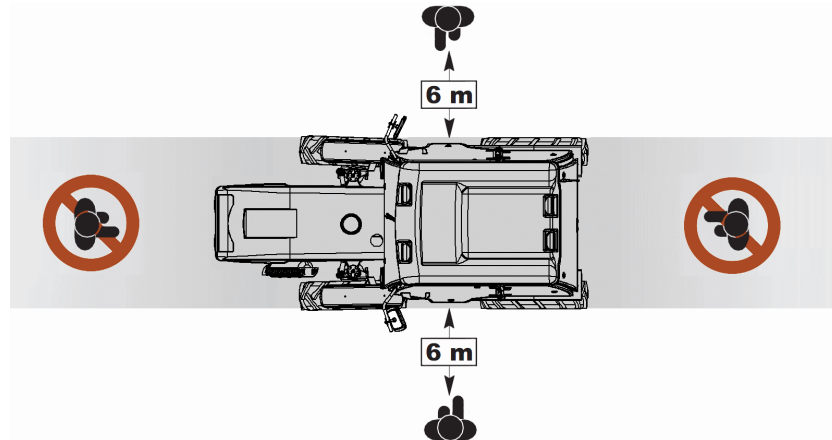

- Do not allow anybody in the vicinity of the tractor, when you are using the loader or suspended load.

2.6.2 STANDARD SAFETY EQUIPMENT

⇒ SAFETY BELT

- Always use safety belt, which ensure safe work and keeps the user in place upon possible tractor roll-over.
Safety belt is NOT used, if you have a tractor without a cabin or lowered roll bar.



	<p>WARNING: Before using the tractor, always check the state of the seat belt, and, if any damage or wear is determined, immediately replace it!</p>
--	---

⇒ ROLL BAR (ROPS – roll-over protective structure)

- The roll bar must always be in upright position, when driving or using the tractor.

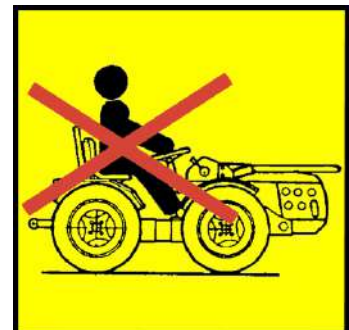

	<p>WARNING: In case of lowered roll bar, the tractor must be on solid, level ground with no incline or obstacles.</p>
--	--

INSTRUCTIONS FOR USE

- Roll bar offers suitable protection only if its construction is intact.
- If the roll bar or its construction is damaged due to tractor roll-over or hitting an obstacle during driving, **replace the roll bar.**
- Roll bar is not intended for towing, therefore, NEVER attach chains or tow ropes, as you risk damaging the tractor or even rolling it over.



	<p>WARNING: Do not change or modify the roll bar, do not cut, drill, straighten or weld its construction, as this reduces its level of safety.</p>
--	---

⇒ SAFETY CABIN (ROPS – roll-over protective structure)

- Safety cabin, installed on the tractor, meets safety requirements according to European guidelines.
- Safety cabin protects/reduces danger of driver injuries in case of tractor roll-over, only if the driver follows all safety instructions and also uses a safety belt.
- Do not change or modify the safety cabin, do not cut, drill or weld its construction.
- If you install additional equipment in the safety cabin, consult qualified persons, who will provide the necessary information.
- If the safety cabin or its construction is damaged in tractor roll-over or if you have bumped an obstacle during driving, **it must be replaced!**



	<p>WARNING: Do not use the tractor in environment where there is possible danger of falling objects, even if the tractor has an installed cabin. In such cases, use of special protective equipment is required (FOPS – falling object protective structure and OPS – operator protective structure), which is NOT CERTIFIED on the tractor!</p>
--	---

2.6.3 STARTING THE TRACTOR UNDER SAFE CONDITIONS

- Before using the tractor, always check that all safety devices (safety belt, roll bar...) are properly installed (firmly fitted) and enable functionality.
- Start the tractor only when sitting in the driver's seat.
- Driver's seat enables rotation function according to desired driving direction (forward or reverse).
- Turn the seat only when the tractor is turned off, NEVER during driving.
- Familiarize yourself beforehand with all control elements, which must be in reach and always in neutral position until using or starting the tractor.

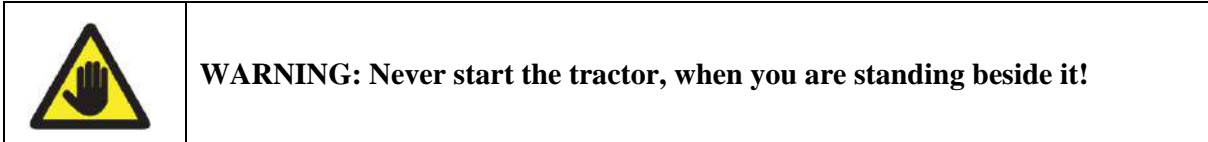

- Do not start the engine by short-circuiting the starter, because the tractor can drive off unexpectedly, if in gear.

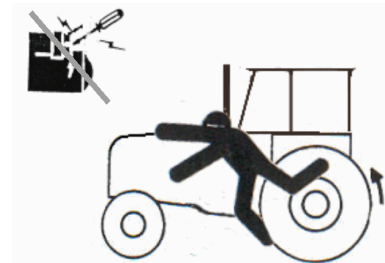

- Before using the tractor, driver's space must be tidy and ensure optimal field of view, without restrictions.
- If there is a cabin installed on the tractor, all windows must be clean before use.



- NEVER leave the tractor running in closed spaces or spaces with poor ventilation. Exhaust fumes, such as CO (carbon monoxide), are potentially extremely dangerous to your health, therefore, always ensure adequate ventilation.



- Be careful, when refuelling the tractor. Turn the tractor engine off and wait for it to cool down before refuelling the fuel tank in a well ventilated area.
- Malfunction can be a cause of fire, therefore, do not smoke while working and make sure that there is no open flame or sparks in the area. In case of spillage, it is mandatory to wipe the spilled fuel.
- Do not fill the fuel tank to the top due to fuel expansion, which depends on the temperature.

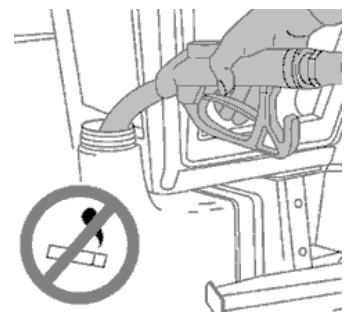

2.6.4 STOPPING THE TRACTOR UNDER SAFE CONDITIONS

Before stepping out of the tractor or leaving it without control, heed to the following safety measures:

- Always lower the three-point hitch;
- If you have installed carried equipment, always lower it to the ground;
- Move all control elements to neutral position;
- Activate handbrake and turn off tractor engine;
- Shift to first gear and remove the key.



2.6.5 WORKING WITH TRACTOR

- Do not begin work until making sure that there are no unauthorized persons in the machine's work area.
- Each unauthorized person, riding on part of the tractor, which is not explicitly designed for that, can:
 - be hurt or can have an accident (falling off the tractor),
 - can have an effect on the driver during tractor use,
 - change tractor's barycentre,
 - obstruct driver's overview and can have an effect on unreliable working conditions on it.

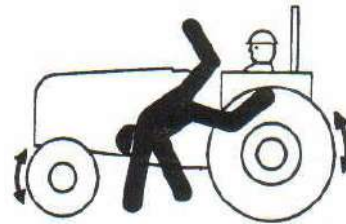
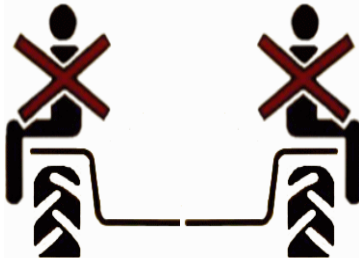

	WARNING: Do not allow unauthorized persons to approach the tractor.
--	--

	WARNING: Driving unauthorized persons on the tractor is prohibited!
--	--

- Safe work with the tractor requires complete attention of the operator, therefore:
 - DO NOT listen to music with headphones during work;
 - DO NOT use your phone during work;
 - Set the installed additional equipment in the cabin beforehand.
- Make sure that you and persons in your area are careful when moving around rotating tractor parts.
- All moving parts (shafts, joints, cylinders, belts etc.) must have protection, which prevents clothing or any body part getting entangled.
- **NEVER remove protection from moving parts!**



	WARNING: Entanglement with rotating part can cause serious or even fatal injury!
--	---

2.6.6 USING THE TRACTOR WITH INSTALLED WEIGHTS

When using the tractor with installed weights, required by circumstances, certain measures must be taken, especially the ones regarding safety.

- Unevenly installed weights significantly affect tractor balance, therefore, always install weights in symmetry, according to type of fitted implement and surface type, where the work is carried out;
- If you weigh the tractor down with water in tyres, do this only if you are qualified for such work, otherwise, leave this to qualified persons;
- When using water weights in tyres in the winter, add antifreeze to water;
- When driving with heavy or long implements, always weigh the tractor down at the front;
- Do not overload the tractor with weight or do not exceed its maximum determined weight;
- When disconnecting implement from the tractor, always also remove weights to prevent tractor instability, reduce wear of vital parts and increase functionality.

2.7 SAFETY INSTRUCTIONS AFTER USING THE TRACTOR

When you have finished using the tractor or parked it for a longer period of inactivity, perform general measures regarding safety.

- Park the tractor on level and solid ground, under covered area or at least with option of covering in a way that does not represent potential danger or hindrance.
- Stop the tractor safely, as described in the chapter "LEAVING THE TRACTOR", and prevent other persons to access control elements in the driver's space.
- Disconnect negative (-) pole from the battery. To prevent electrolyte freezing, disconnect the battery from the tractor for the winter period and store it at suitable room temperature.



2.8 USING THE TRACTOR ON SLOPES

- Avoid working with the tractor on uneven ground, slopes or banks. Be very carefully when driving near ditches or holes.
- When driving on a slope, do not shift into neutral position and do not press the clutch pedal.
- When driving on a slope, always use suitable speed with suitable gear, especially when driving heavier loads or work implements. Do not drive or stop abruptly and avoid sudden turns to prevent the tractor from rolling over.
- Connect towed implement or trailer only to original tractor connection.
- Make sure that the towed implement is always lighter than the tractor.

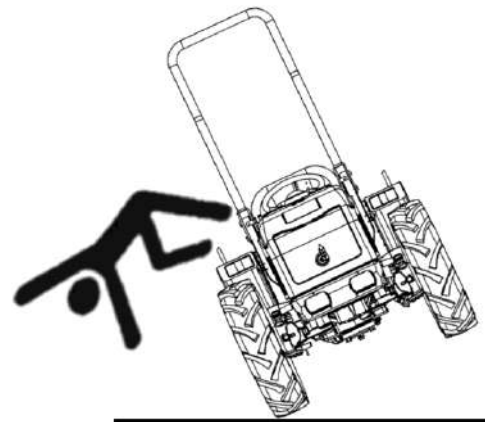

- Driving the tractor, loaded with a very heavy towed implement, must be done in reverse on very steep slopes. Otherwise, the front end of the tractor can lift due to overload and can cause the tractor to roll over.
- Do not drive the tractor transversally on slopes, as you risk rolling it over. If possible, drive only uphill and downhill.



WARNING: When working on a steep slope, make certain of ground firmness, especially in bad weather conditions.

- When braking with towed implement, especially when driving downhill, consider its length, width and weight, as these are key for stability and their factor can greatly extend braking path in correlation to tractor speed.

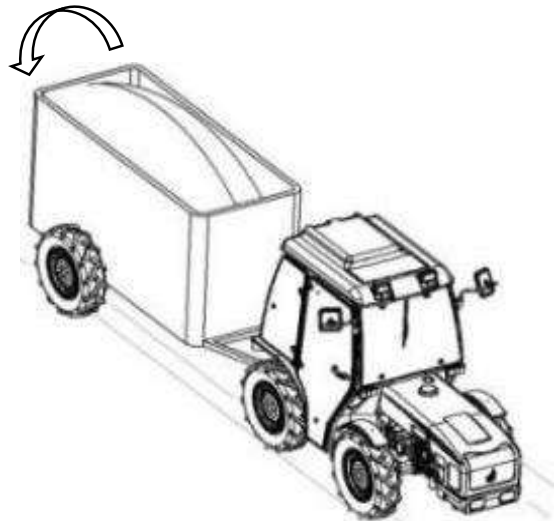

2.9 USING IMPLEMENTS

- Connect implements only to designated points on the tractor. Do not connect implements, which do not meet all safety conditions of use when:
 - Lacking proper signalling;
 - Lacking suitable safety devices;
 - Tractor capability does not meet implements.
- If you are using the tractor with fixed implement in connection with cardan shaft, always:
 - Leave the tractor running in idle or shift to neutral gear position;
 - Activate handbrake;
 - Place wedges under tractor wheels.
- Do not overload the tractor with implement. If there is great load, ensure proper stability of the tractor by adding appropriate weights.
- Keep in mind that the weight changes with implement, which decreases braking effect, which has a substantial influence on longer braking path.
- Do not connect electricity or hydraulics, when the tractor is operating.



WARNING: If there are additional implements installed on the tractor, which change weight distribution, adapt you driving to current conditions!

2.9.1 CARRIED IMPLEMENTS

- Connect carried implement to tractor's three-point hitch and secure it with pins. Implement and tractor must be at the same height to connect them with cardan shaft.
- Always make sure of tractor stability, when connecting carried implement. For this purpose, instructions for use include calculation formulas to determine suitability.
- Familiarize yourself with proper use of carried implement before using it on the tractor. For this purpose, read its instructions for use and maintenance.

2.9.2 TOWED IMPLEMENTS

- Connect towed implement to tractor's towing hook.
- Do not connect towed implement to tractor's three-point hitch system, as it is intended only for carried implements. Otherwise, you risk tractor roll-over.
- You can tow implements on the tractor without brakes or implements fitted with mechanical brakes. When driving with towed implements without brakes, especially when stopping, consider total weight of the tractor and towed implement or load, because you can very easily lose control of the tractor.
- When leaving the tractor with connected towed implement, repeat procedure from chapter "STOPPING THE TRACTOR UNDER SAFE CONDITIONS", and, in case of slope, always install safety wedges under the wheels of tractor or trailer.



WARNING: Do not allow unauthorized persons to be between the tractor and implement, when it is operating or when you are connecting or disconnecting the implement.

2.9.3 CARDAN SHAFT

Drive elements can cause serious accidents, therefore, heed to the following instructions:

- For driving elements on the implement (pump, fan countershaft etc.) use cardan shaft, which is equal to defined shaft for this implement according to size and construction and is fitted with safety cover.
- Before first use, check cardan shaft to make sure that its length is not too short or too long, so that it does not come off or gets stuck during start.
- First, connect the cardan shaft to the implement and then to tractor's drive shaft (PTO).
- When fitting the cardan shaft, make sure that the safety pin is locked into place. Push and pull the cardan shaft forwards and backwards, until the safety pin locks into place.
- Connect the implement to the tractor only when the drive shaft (PTO) is disengaged.
- Connect and disconnect the cardan shaft **only when the engine is off and ignition key removed from its switch.**
- Before engaging the drive shaft (PTO), check number of revolutions and make sure that there are no people or animals in the danger area.
- Do not engage the tractor's drive shaft (PTO) for any reason and check that the angle difference on cardan joints is not too great.
- Outlet drive shaft (PTO) of the tractor can be manually turned when installing the cardan shaft, when the engine is off and the cardan shaft is disengaged.
- Rotating shafts without protection are very dangerous!

- Always make sure that safety elements are in place and cover all rotating parts, including "crosses" of the cardan shaft on both ends! Do not use cardan without protection!
- Do not touch rotating cardan shafts! Safety distance from rotating cardan shaft is 1.5 m.
- To ensure long life expectancy of the cardan, avoid using angles greater than 15° when working.
- Protect safety elements from rotating with chain!
- Make sure that cardan shaft protections on the tractor and implement are joined (fastened)!



WARNING: Install the cardan shaft according to order implement → tractor. Never connect the other way around, as this may cause serious injury or even death!

2.10 USING THE TRACTOR ON THE ROAD

Do not drive the tractor on public roads, but if you do, observe the following instructions:

- When driving with the tractor, heed to road traffic regulations;
- Before driving, make sure that the brake pedals are connected;
- If you want to use the tractor in road traffic, it must be fitted with road signalling and signs, as defined by road traffic regulations;
- Check that the light signalling on the tractor and implement (if in use) works flawlessly;
- Check condition of tyres (pressure and wear);
- Do not use differential lock when taking off or driving on the road;
- Lift mechanism must be fixed in top position during driving;
- If you drive the tractor with an implement, reduce speed to take into account that braking paths (depending on weight) significantly increases and do not brake or turn suddenly;
- When driving the tractor on the road, the seat must always be in normal position, never reverse;
- During driving, always adapt to traffic and conditions on the road;
- If you are driving in road traffic, do not engage the cardan shaft – do to this only when working;

2.11 TRANSPORT OF TRACTOR

Tractor can be transported by towing with another vehicle or by loading on a transport vehicle.

2.11.1 TRANSPORT

- Transport of tractor must be performed by persons, who have been instructed beforehand or have appropriate knowledge and skills;
- Transport of tractor must be performed in accordance with instructions set by the manufacturer in the instructions for use;
- Before transport, make sure that all parts are safely secured to the tractor and that all opening parts are correctly closed;
- When transporting, always use suitable loading ramps, which ensure safe execution of the entire procedure of loading and later unloading from transport vehicle;
- Loading ramp must have a side safety edge, which prevents the tractor to slide to the side when loading or unloading;
- Always make sure that the loading ramp is secured firmly to transport vehicle and on ground and that there is no dirt, oil, ice etc. on it, as this may cause uncontrolled sliding. In this case, clean the surface of loading ramp before loading and unloading;
- Do not load the tractor with a hoist or a forklift. For safe loading, use a towing bar or towing chain with a winch, which must be correctly connected to tractor's connection points;

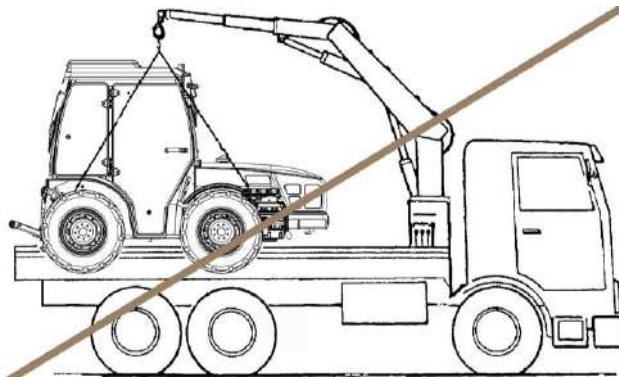

- During loading and unloading, an additional person must be present to give safety instructions from a safe distance;
- Tractor must be secured properly on the transport vehicle, as stated in the instructions for use;
- If the loaded transport vehicle exceeds external measurements, make sure that all signals and warning lights are in appropriate position and function perfectly, if required by local legislation.

2.11.2 TOWING

- Towing should be performed only in case of tractor malfunction and only for short distances;
- When towing the tractor, heed to the maximum allowed speed, which is 10 km/h.
- When towing the tractor, always keep warning lights or other devices for better signalling turned on, in accordance with road traffic regulations in force.



WARNING: During loading or unloading, never stand in immediate vicinity.

2.12 MAINTENANCE

In the period of tractor operation, maintain it regularly, as foreseen by the manufacturer. Correct maintenance ensure long operating period of the tractor and suitable safety.

Before starting maintenance work on the tractor, shut down the engine, remove the key and engage the handbrake and wait for the tractor to cool down:

- Inform yourself on servicing or leave to adequately qualified personnel.
- Keep the work place clean and dry.
- Do not lubricate, repair or set the tractor when in motion! Do not touch moving parts! Shut off power and make sure there is no work pressure in the hydraulic circuit!
- Maintenance and servicing should be performed when the tractor is cleaned.
- During maintenance and servicing of the tractor, disconnect all implements.
- Use only suitable tools for servicing.
- Disconnect tractor's drive shaft (PTO) to prevent sudden turning on and operation of the machine.
- Do not check the tractor without "engaging" safety elements.
- Support the tractor for repair or maintenance, so there is no uncontrolled movement.
- Support and install safely all parts, which need to be raised during service.
- Maintain machine parts in good condition. Remedy problems immediately. Replace worn out and damaged parts. Remove excess oil, grease or any other filth.
- During tractor repair, use protective equipment.



**PROHIBITED REPAIR
DURING OPERATION!**



WARNING: Do not perform maintenance work on the tractor, when it is operating. Stop the tractor under safe conditions!

2.12.1 HYDRAULIC SYSTEM

Check the condition of hydraulic system (joints, tubes), especially tubes going to hydraulic cylinders of steering system.

- Do not use open flame near tubes under high pressure. Damage to any tube under high pressure can cause flammable liquids (fuel, oil) to escape and thus causing severe burns.
- Liquids, coming out of the tubes, can be under high pressure and can damage skin and, if they get under the skin, can cause serious injury.



- Never try to disassemble hydraulic tubes or other hydraulic lines, when they are under pressure. Before using the hydraulic system, make sure that the connection is safe.
- When determining hydraulic circuit leakage position, use cardboard for help. If you are dealing with high pressure circuit, protect your arms and body.
- In case of injury, seek medical attention. Due to danger of serious injury, any penetration of liquid through the skin must be stopped and the liquid must be removed in a matter of hours.

2.12.2 BODYWORK

Do not heat painted parts of the tractor, as this creates toxic gases, which are harmful to health. When repairing painted parts of the tractor with welding, soldering or heating, remove the paint first with sanding!



2.12.3 WHEELS

Regularly check that wheel nuts are tightened properly. When tightening, use correct torque. Table with torque values for tightening is provided in the instructions for use in the chapter Maintenance.

When repairing rim due to damage, always remove the tyre beforehand. If you do not have suitable equipment, leave this task to qualified person.

	<p>WARNING: Never repair rims with tyres still on, because tyres can explode with compressed air!</p>
--	--

2.12.4 COOLING SYSTEM

Before inspection, shut down the engine and wait for it to cool down. When the engine is warm, cooling liquid in the tank is under pressure and can cause burns, if you open the cover.



	<p>WARNING: Always refill cooling liquid when the engine is cold!</p>
--	--

2.12.5 ELECTRICAL SYSTEM

Before performing any setting or repair on the electrical system, or if you weld on the tractor, disconnect connections (negative cable -) on the battery.

Be careful, when handling the battery:

- Make sure that you connect poles from the battery to tractor correctly;
- Never connect battery poles with each other, as this may cause explosion;

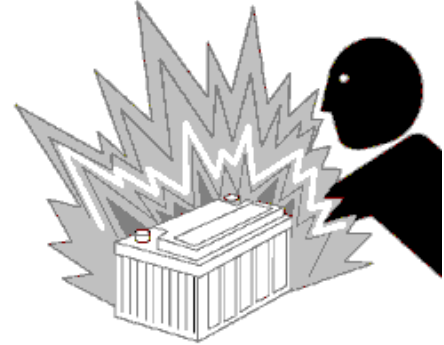

- Battery acid is toxic and corrosive. Therefore, it can destroy clothes, burn skin or, if sprayed into eyes, cause blindness.

Follow these recommendations:

- charge the battery in a well ventilated area,
- when charging the battery, do not keep it near fire (welding) or smoke near it,
- use protective goggles and rubber gloves for work,
- when adding electrolyte, do not inhale toxic gases.
- If spilled with electrolyte:
 - wash skin with water;
 - undress spilled clothes;
 - apply baking soda to neutralise the acid;
 - if electrolyte came into contact with your eyes, wash them for 10-15 minutes with water;
 - immediately seek medical attention.
- If drinking electrolyte:
 - drink a lot of water;
 - drink magnesium milk, whipped eggs or vegetable oil;
 - immediately seek medical attention.
- In case of suspicion of poisoning (signs: sweating, dizziness, depression, headache, nausea):
 - immediately stop work;
 - undress wet clothes;
 - stay calm;
 - lay on your side;
 - immediately call medical attention.

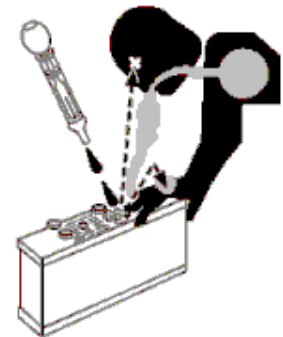

2.12.6 ENVIRONMENT PROTECTION (RECYCLING)

All companies must foresee, assess and then control the effect of their products and services on the environment.

Regard the following factors to determine effects on the environment:

- Emissions in atmosphere
- Discharge of waste liquids
- Waste management
- Ground pollution
- Use of raw material and waste sources
- Related local problems regarding environmental pollution

To reduce these effects on the environment, the manufacturer suggests some general measures, which must be followed by everybody operating the tractor in its life span.

- When performing maintenance tasks on the tractor, be careful not to pollute the environment with worn out parts or waste.
- Uncontrolled discharge of chemicals in the environment is **strictly prohibited!**
- Pour waste liquids in designated containers and dispose of them in accordance with regulations of local legislation.
- When the tractor is no longer to be used, it must be cleaned completely, disassembled and sorted according to material of individual components and handed over to waste management organization.
- Plastic components can be recycled or incinerated in designated incineration devices, and metal parts can be separated as scrap iron.



IMPORTANT: Incorrect recycling or disposal is fined by legally set sanctions!

2.12.7 NOISE

The tractor, as well as the connected implement, creates certain level of noise during operation.

- Excessive noise can cause severe hearing damage, therefore, the greater the noise level and the longer the noise is present, the greater the risk. Instructions for use include information about the noise level of your tractor.
- If the noise level exceeds 85 dB(A) or if the user is exposed to noise for a longer period, use of hearing protection is recommended (anti-noise plugs or headset).
- Noise level can vary depending on the implement that you are using and revolutions of the connection shaft.

2.13 USING THE TRACTOR FOR SPRAYING

Tractor operator must be familiar with regulations regarding plant protection, therefore, always read instructions for use on the chemical substances. Heed to regulations, safety measures and use instructions:

- When working, keep cabin windows and doors closed and use respiratory protection, such as gas mask or helmet with fresh air.
- When preparing chemical substances, dress appropriately. When working, use protective mask, gloves, boots and protective clothing. Take care of your protective equipment. Do not use "worn out" protection.
- If you see people in the work area, who are potentially exposed to inhaling chemical substances, immediately stop spraying.
- After use, clean the spraying device and store it in a suitable area, so that it is inaccessible to unauthorized persons.
- Make sure that your tractor and spraying device are regularly cleaned, as this reduces the risk of direct contact with chemicals.
- After spraying, clean the tractor (if required) and spraying device at an appropriate place, so that chemical substances do not get into the environment.
- Make sure that your protective equipment and clothing are well maintained and cleaned. Dirty gas mask can cause skin irritation. Regularly replace the filter!
- Store protective equipment in a dry, cold and clean place. Never store protective equipment in the same place as chemicals. Your protective clothing for chemicals must be stored separately from other clothes. Protective equipment, which gets dirty with chemicals during work, should be cleaned in accordance with regulations on cleaning dangerous substances.



WARNING: Do not begin spraying until you have put on personal protective equipment, even if your tractor has a protective cabin!

It is desired that the tractor has a hermetically sealed cabin during spraying, in which overpressure can be created with ventilation of fresh air, which disables chemically polluted air to enter the cabin. **Because the tractor does not have a suitable cabin installed, which would enable this or the cabin is NOT CERTIFIED, the tractor is not suitable for such type of work!**

2.14 USING THE TRACTOR IN FORESTRY

When using the tractor in forestry, you must consider dangers, which happen most often when trees, branches or other objects fall or penetrate the driver's space.

When doing forestry work, the tractor must be well-positioned and stable. Ensure this in any case (support wedges, weights etc.).

Protective cabin on the tractor is not intended for forestry work, is NOT CERTIFIED and does not meet the conditions of use as protective equipment FOPS – falling object protective structure and OPS – operator protective structure.



WARNING: Do not use the tractor in forestry, if there is danger of material falling or penetrating from the side!

2.15 FRONT LOADER

- Front loader must be equipped with suitable support device, which, with raised lift arms, prevents the load to slide in driver's area.
- Objects, which are not secured properly on the loader, can, during lifting, fall on persons standing in direct vicinity of the tractor.
- When transporting objects with front loader, you must lower the bucket as close to the ground as possible.
- When driving downhill with loaded front loader, drive downhill in reverse.
- If you drive with front loader on uneven ground, reduce tractor speed to prevent loss of steering control.



WARNING: The tractor does NOT HAVE CERTIFIED protective safety equipment for work with front loader, therefore, it is not suitable for such work!

2.16 ADDITIONAL SAFETY REQUIREMENTS

This chapter describes additional danger or risks, which often occur and of which you must be especially aware of as user, despite being already described in the instructions for use and you have already considered or anticipated them.

- **Danger of loss of stability:** To prevent loss of tractor stability, the user must drive safely and responsibly, especially when there are implements or weights or both on the tractor, near ditches or on slopes, on soft and uneven ground in bad weather conditions.
- **Danger of tripping:** The user must be careful before entering or exiting the tractor not to trip against control units or slip in case of dirty surfaces. Therefore, it is recommended to use three-point grip when entering or exiting the tractor.
- **Danger of impact:** The user must always connect or disconnect the cardan shaft correctly, therefore, he must heed to correct order and follow the procedure of connection implement → tractor and disconnection tractor → implement to prevent dangerous impact, which can cause severe injuries or even death.
- **Danger of crushing:** When connecting or disconnecting an implement, the user must always be in the safe zone of the driver's seat and must not allow other persons to approach during the process.
- **Danger of cuts:** The user must not reach his hand toward rotating fan or other moving parts without suitable safety protection. If performing maintenance tasks, stop the tractor first under safe conditions.
- **Dangerous substances:** The user must not use the tractor in closed or poorly ventilated areas, where he risks poisoning with exhaust gases (carbon dioxide CO₂). In case of handling chemical substances, always use protective equipment (face mask), even in case of installed cabin with suitable filters.
- **Danger of pulling:** Do not approach rotating mechanical parts of the tractor, such as front (optional) and rear cardan shaft, because trouble can arise quickly with serious injury or even death.
- **Danger of scratching:** The user must never touch rotating wheels or other rotating parts in his reach during driving.
- **Danger of burns:** The user must never touch the engine, when it is running and creating heat. Parts of the engine, such as the block, radiator and especially exhaust pipe, heat extremely during operation and can cause burns upon contact. Before touching them or performing maintenance tasks on them, wait for them to cool down.

2.17 SAFETY SIGNS ON THE TRACTOR



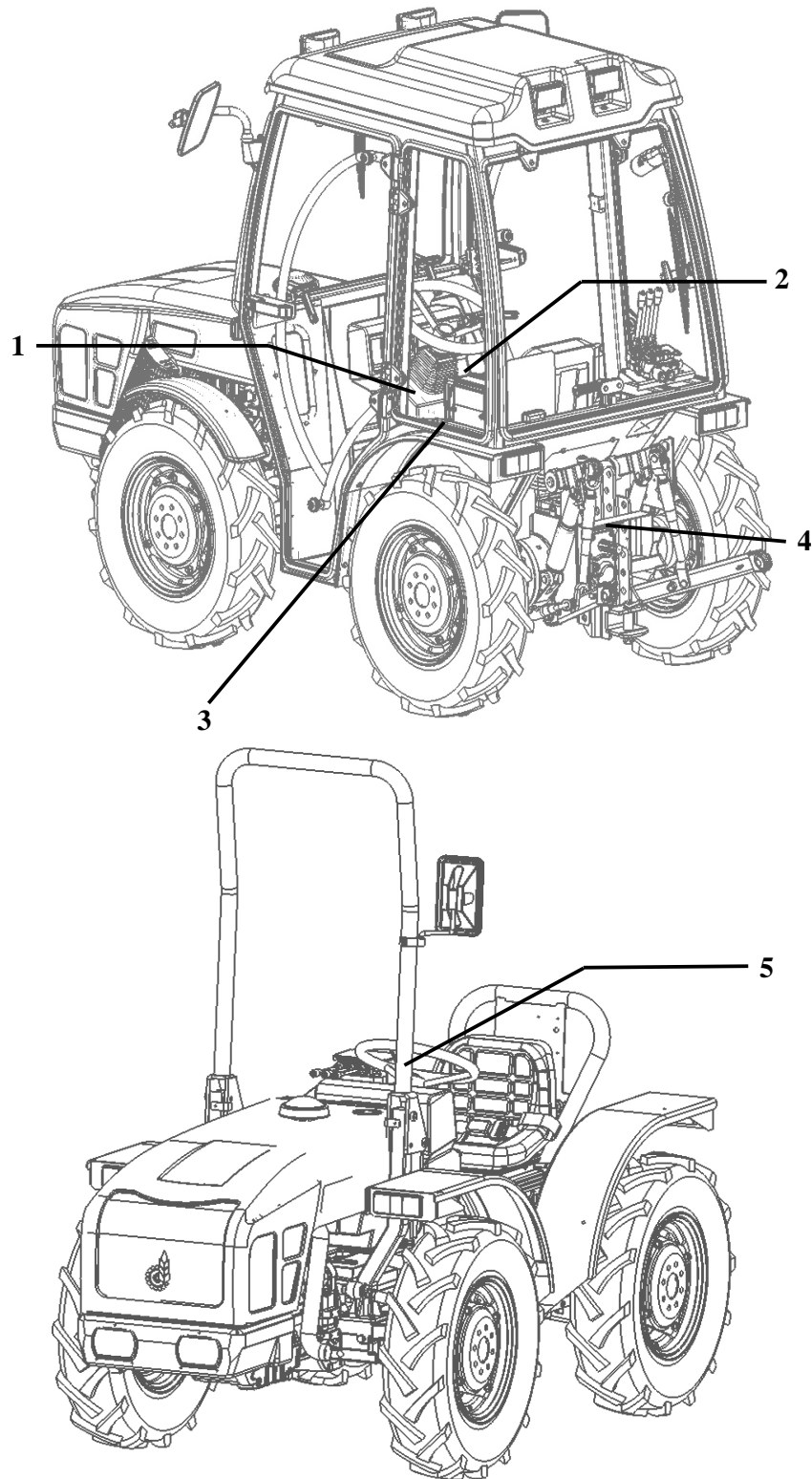

On the tractor and in the instructions for use are safety and warning signs. To ensure your safety, take a closer look at them. Follow instructions and advice regarding safety measures, provided in the previous chapter.

Ensure that safety signs are visible. Ensure that you have all required signs after servicing or replacement of parts. Safety signs are available at authorized dealers.



2.17.1 MEANING AND POSITION OF SAFETY SIGNS

Learn to operate the tractor well and never allow it to be operated by a person not familiar with the instructions! The table below describes individual safety signs.

	Position	Description	Sign
1.) General danger	Sign is positioned on the left side of driver's console under the steering wheel.	Sign represents general danger or danger of possible injury due to noncompliance with instructions.	
2.) Key removal	Sign is positioned on the right side of driver's console under the steering wheel.	Before each intervention or repair, shut off the engine and remove the key from its lock. Warning: Before first use of the tractor, read instructions for use!	
3.) Danger of pulling	Sign is positioned on the protective part of rear connection shaft.	Sign shows danger of entanglement with rotating part (cardan shaft), so be careful and do not approach rotating drive shafts!	
4.) Danger of fall	Sign is positioned on the rear left track of the tractor (with or without cabin).	Sign represents danger of persons falling, so do not transport persons, who are not sitting appropriately on the tractor!	
5.) Danger of roll-over	Sign is positioned on the left lower side of roll bar.	Sign represents danger of serious injury, which can occur in roll-over, if the roll bar (ROPS) is lowered. Never drive with the roll bar lowered!	

3 TECHNICAL SPECIFICATION

3.1 MANUFACTURER'S INFORMATION

Type plates are fitted on the right side of the tractor.

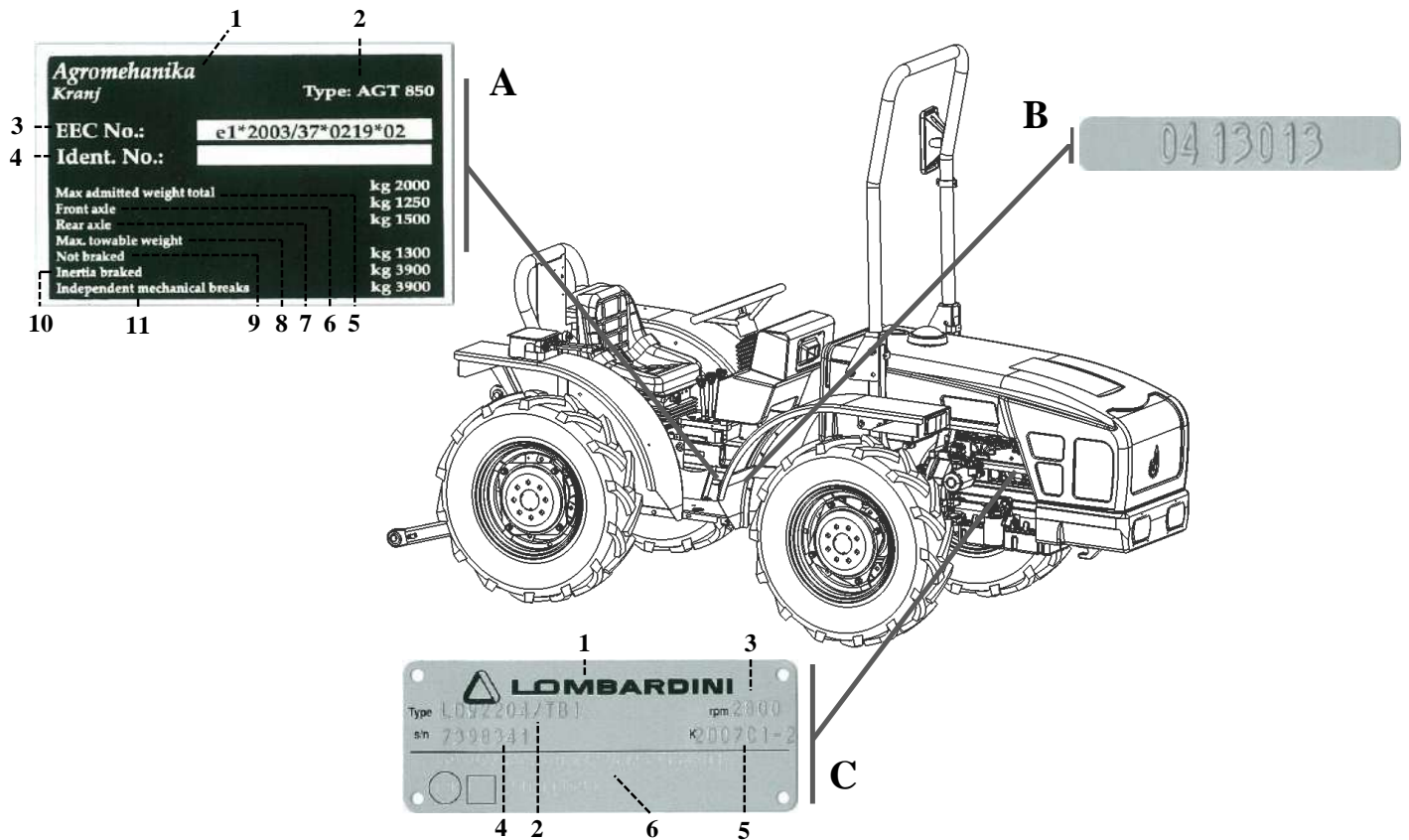

A – Type plate with information about the tractor and manufacturer (fitted below the steering wheel on the intermediate part of transmission).

Type plate includes the following information:

1. Manufacturer;
2. Type of tractor;
3. EC number of tractor conformity;
4. Identification number;
5. Maximum admitted weight total;
6. Admitted weight on the front axle;
7. Admitted weight on the rear axle;
8. Maximum admitted weight of implement;
9. Admitted weight of implement without brakes;
10. Admitted weight of implement with inertia brakes;
11. Admitted weight of implement with independent brakes.

B – Type plate with identification number of manufactured tractor (fitted below the steering wheel on the intermediate part of transmission).

C – Type plate with information about engine (fitted on the right part of engine block).

Type plate includes the following information:

1. Manufacturer
2. Engine type
3. Maximum number of revolutions
4. Serial number
5. Customer number
6. EC number of engine conformity

3.2 REPLACEMENT PARTS

Manufacturer ensures flawless and long-lasting operation of the tractor, of course, with original replacement parts installed. In case of installing and using non-original parts on the tractor, the performance can decrease substantially, repair costs increase and the manufacturer does not guarantee for material damage and personal injuries, which occur due to such action.

When using non-original parts, tractor warranty can also expire, therefore, use only original replacement parts or accessories, delivered by company Agromehanika d.d.

In case of any malfunction or damage on the tractor, the manufacturer ensures required service and provides reliable technical support with its expert staff.

For you, as owner, to be familiar with all information about your tractor in case of contacting technical services, write down the following information below:

Information about your tractor:

Tractor model _____

Tractor serial number _____

Engine model _____

Engine number _____

Year of manufacture _____

Phone number of sales unit _____

4 GENERAL DESCRIPTION OF TRACTOR

AGT 850 series tractors are intended for different requirements or tasks in agriculture, gardening, forestry, and can also be used in municipal services with a few technical accessories.

Thanks to its rigid transmission with different width, small turning radius, wide four-wheel drive and low centre of gravity, tractors are also suitable for work on sloping ground.

For different work, the tractor is equipped with:

- rear hydraulic lift system with three-point hitch;
- towing connection;
- drive shaft;
- hydraulic connections.

As option or according to work requirements, the tractor can be fitted with front hydraulic system with three-point hitch.

This makes tractors suitable for a wide spectre of tasks.

Tractor can be operated by a single operator, who must follow all instructions for safe use consistently.

Tractor is distinguished by:

- constant four-wheel drive;
- rigid transmission version;
- synchronized gearbox;
- option of choosing driving direction by turning the seat with the steering wheel;
- large offer of suitable rims and tyres;
- braking of all four wheels through constant drive;
- adjustability of wheels and drive to different terrain types;
- small turning radius;
- locking of both differentials;
- low operation costs;
- easy and safe use and simple maintenance.

4.1 DESCRIPTION OF TRACTOR'S MAIN COMPONENTS

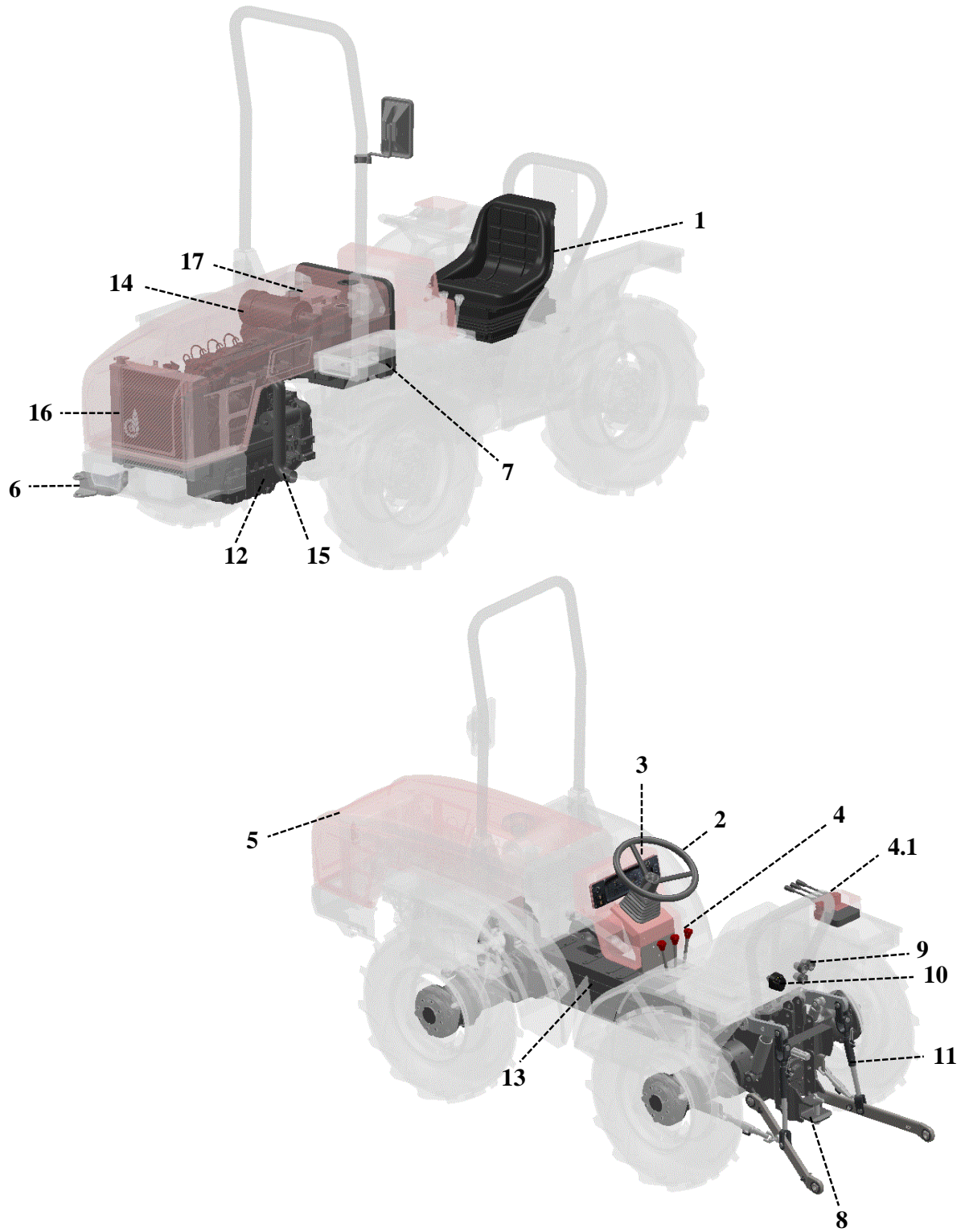

1. Driver's seat

Driver's seat is manufactured according to ergonomic principles, which means that it is adaptable to work environment of the user, according to his physical features. The seat is positioned so that the user has complete overview and simple control of control elements.

2. Steering wheel

Steering wheel is hydraulically controlled and enables steering of front two wheels.

3. Dashboard

Dashboard is consisted of different control devices (speedometer, water gauge, fuel gauge), control lights and control elements.

4. Control elements



Control elements, connected to synchronized gearbox, with which speed and direction of driving can be set.

4.1 Control elements of hydraulics

Control elements of hydraulics control lift mechanism and implements, carried or towed. Control elements are connected to the hydraulic system, which is built in the tractor and runs all main components. Hydraulic system is driven by gear pump, which is driven by the engine.

5. Engine cover

Engine cover protects the user or prevents contact with moving parts, such as belts, radiator fan etc.

	WARNING: If the tractor was running, be careful with hot surfaces when opening the engine cover!
	WARNING: Open the engine cover only when the tractor is stopped. Do not allow unauthorized persons to open the engine cover!

6. Front towing hook

Front towing hook is intended for towing the tractor in case of malfunction.

7. Tank

Tank contains fuel for engine supply.

	IMPORTANT: Fill the tank only with diesel fuel!
---	--

8. Towing hook

Towing hook is intended for connection and towing of towed implements.

9. Rear hydraulic couplings

Hydraulic couplings are intended for quick connection of implements with hydraulic system.

10. Rear electrical connection

Electrical connection from standard 7-pin electrical socket, for connecting electrical system of implement (trailer).

11. Rear lift mechanism

Rear lift mechanism with three-point connection is intended for connection and lifting of carried implements. It is available in different versions according to work requirements and demands of the customer.

12. Engine

Diesel engine with internal combustion is the main drive element of the tractor.

13. Transmission

Reversible version of tractor – R

Transmission has constant four-wheel drive and enables locking of both differentials.

- Front axle, wheel reducer on each side and hydraulic differential lock.
- Rear axle, wheel reducer on each side and hydraulic differential lock.
- Connection shaft, intended for driving towed or carried implements through tractor.
Connection shaft has an electro-hydraulic clutch and can operate with independent speed or speed, which is synchronized with shifting gearbox gear or revolutions of tractor engine.

Irreversible version of tractor – NR

Transmission has constant four-wheel drive and enables locking of both differentials.

- Front axle, wheel reducer on each side and mechanic differential lock.
- Rear axle, wheel reducer on each side and mechanic differential lock.
- Connection shaft, intended for driving towed or carried implements through tractor.
Connection shaft has gear transmission and operate dependent of main clutch or with speed conditioned by two gear ratios, with shifting gearbox gear or revolutions of tractor engine.

Gearbox, synchronized with 4 gear and 3 speed groups with inverter, which enables change of movement direction, 12 forward speeds and 12 reverse speeds, total 24 speeds.

14. Air filter

Air filter prevents entry of larger particles in engine suction system.

15. Exhaust

Exhaust (silencer) is intended for guiding exhaust gases and reducing noise in the environment.

16. Radiator

Radiator is intended for dissipation of heat, which is created in working engine due to internal combustion.

17. Battery

Battery is intended for electrical supply of different elements of the tractor.

4.2 DESCRIPTION OF MAIN SAFETY COMPONENTS

4.2.1 CABIN

Figure presents main cabin components.

Cabin is available in two types:

- **Standard version**
- **Wide version**

– **A) Cabin**

Cabin is fitted on four points – in the rear on left and right sleeve and in the front on intermediate part of transmission, which enables easier disassembly or assembly in case of repair or replacement. The cabin has its own control elements, which are independent of other tractor elements.

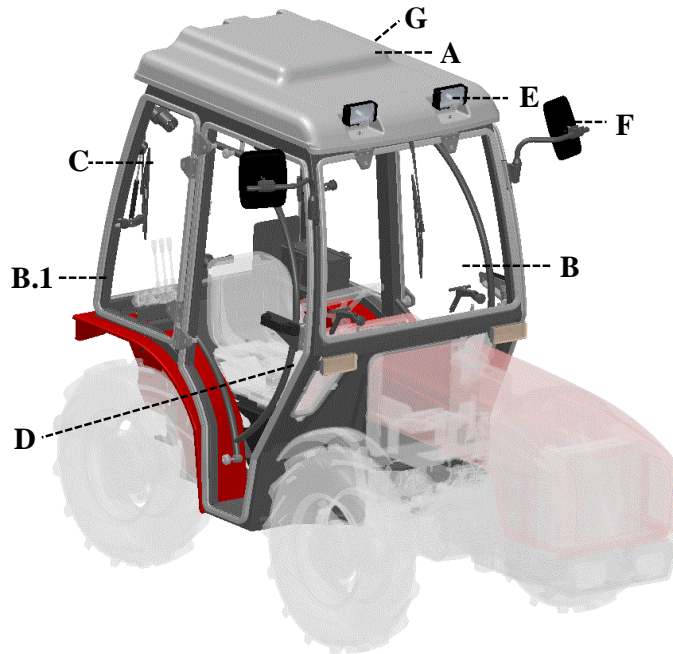

– **B) Front windshield**

	<p>WARNING: Protective cabin is not tested against falling objects or material protrusion, therefore, it is NOT CERTIFIED and does not conditions of use as protective equipment FOPS – falling object protective structure and OPS – operator protective structure!</p>
---	---

Front windshield is made of tempered glass and it opens out from below, through top hinge (1) and bottom mechanical lever (2).

Front windshield is equipped with one central fitted wiper (3), controlled by individual connection in the cabin.

Front windshield is wider in wide cabin version.

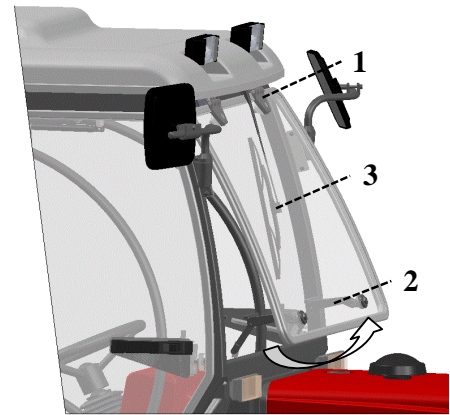

– B.1) Rear windshield

Rear windshield is made of tempered glass and it opens like front windshield, through top hinge (1) outwards from below. The only difference is that it does not open with mechanical levers, but with gas springs (2), which automatically open the windshield to maximum travel of gas spring after releasing bottom lever (3) up.

Rear windshield is equipped with one wiper (4), fitted on the right side and controlled by individual connection in the cabin.

Rear windshield is wider in wide cabin version.

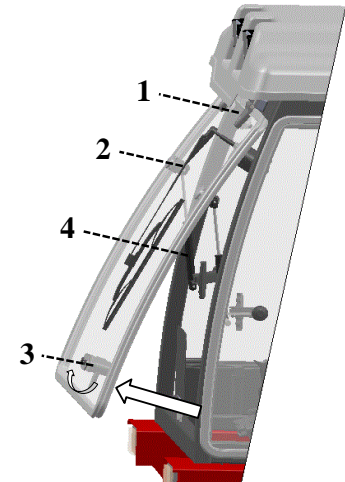

– C) Side window (rear)

Side window is made of tempered glass and it opens to the side through lateral hinges (1) and mechanical lever (2).

– D) Doors

Doors are installed on both sides of tractor cabin. They are designed to enable the best possible entry and exit for the user or operator. Each door is equipped with a lock.

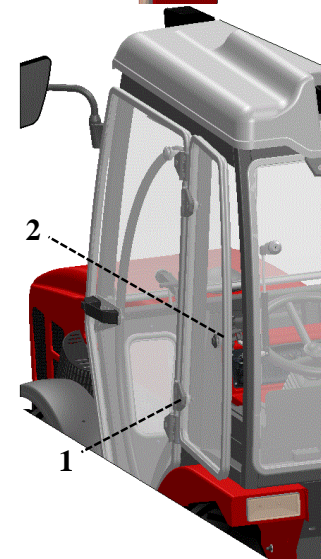

If the lock is unlocked:

- To open the doors from the outside, press button (1) on the handle and pull the doors towards yourself.
- To open the doors from the inside, pull the handle (2) on the mechanism towards yourself and open the door.

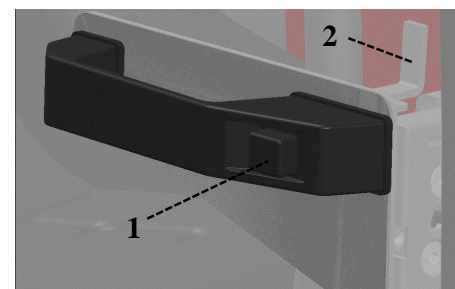

– **E) Work lights**

Lights can be manually adjusted under different angles for optimal lighting of certain area.

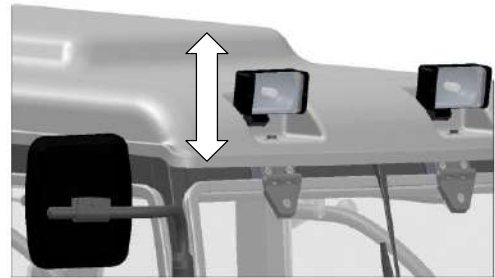

– **F) Rear-view mirrors**

Set rear-view mirrors accordingly for safe control of the tractor and implement during driving.

Rear-view mirrors are set correctly, when the driver see sides of the tractor and implement without trouble.

Rear-view mirror setting:

– **Horizontal setting**

To set the mirror horizontally, unscrew bolt (1) on holder, then move the mirror on the bar (2) left or right, until you set desired position. When the setting is done, tighten the bolt on the holder.

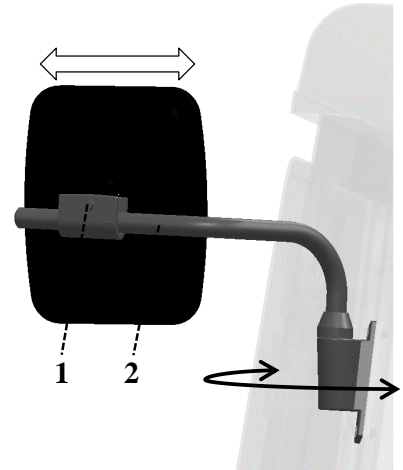

Mirror bar also enables turning around the axle. You can turn them completely in or out in case of tight space. With each move, bars lock into certain intermediate position.

– **Setting mirror for defined angle**

Because the mirror is fixed in the centre of the holder, the mirror can be set at will at different angles (option of turning for 360°, forward or backward, left or right).

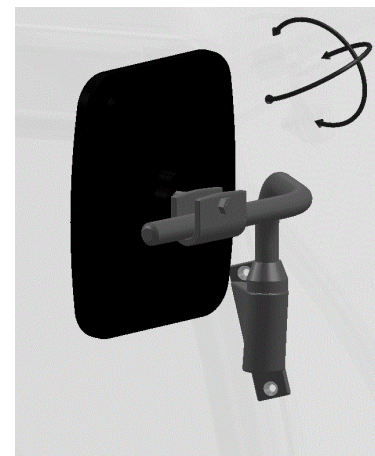

– **G) Rotation light (option)**

Rotation light is used on tractor with tractor implements exceeding tractor width or on tractors with carried tractor implements, rear edge of which reaches more than 1.5 m over the rear edge of the tractor.

In this case, an additional warning light is used, which is installed on the rear part of the implement.

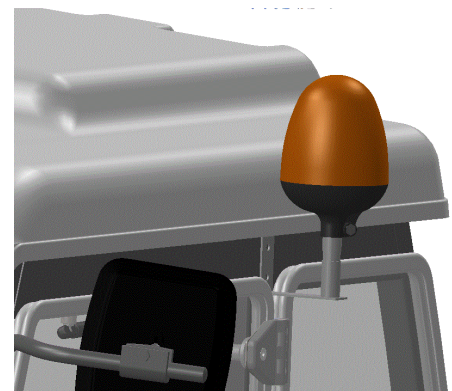

4.2.2 ROLL BAR

The tractor is, as standard, equipped with two roll bars, which, together, form suitably safe protection for the driver in case of any accident or tractor roll-over.

	<p>IMPORTANT: Roll bars (ROPS) have been tested according to standard O.E.C.D. and offer suitable protection for the driver or user in case of roll-over.</p>
---	--

Figure shows main components of tractor with roll bar.

– **A) Front roll bar (ROPS)**

Front roll bar is constructed so that it can be moved to horizontal position.

Do this only when work requires it, on flat ground, with no danger of rolling over and on a short distance.

In case of lowered roll bar, the driver must not fasten his seat belt. Therefore, he must be very careful when driving, because there is no protection with any safety element again possible roll-over. The driver or user must not, in any case, drive the tractor with lowered roll bar on roads intended for public road traffic.

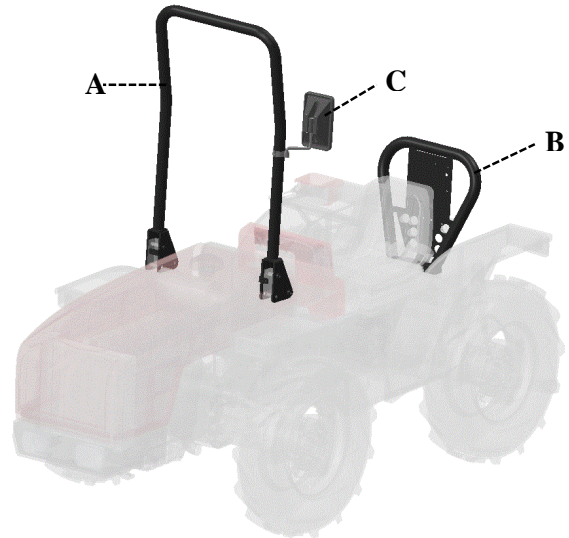

	<p>WARNING: When the roll bar is lowered, the driver MUST NOT use the safety belt!</p>
---	---

	<p>WARNING: The tractor is not to be used:</p> <ul style="list-style-type: none"> - if the roll bar is not installed properly; - if the roll bar is damaged; - if modifications have been made to the roll bar. <p>In this case, replace the roll bar with a new one!</p>
---	--

– **B) Rear roll bar (ROPS)**

– **C) Single rear-view mirror**

Set rear-view mirror accordingly for safe control of the tractor and implement during driving.

Rear-view mirrors are set correctly, when the driver see the rear of the tractor and implement without trouble.

Setting rear-view mirror:

- Setting mirror for certain angle
Mirror bar enables turning around the axle. You can turn it completely in or out in case of tight area. With each desired move, you must unscrew bolt (1) on the joining point of bar and holder first.
- Vertical setting
As the mirror is fixed in the centre point of the holder, you can set the mirror also vertically (movement option up or down).
To set the mirror, first remove both plates (2), unscrew the bolt on the holder and then rotate the mirror on the bar (3) left or right, until you set the desired position.
After setting, screw the bolt back and fix the plates.

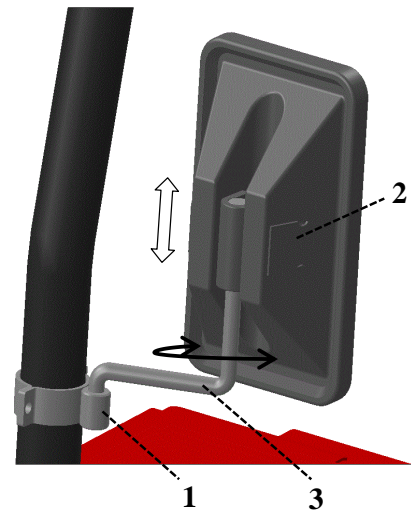
**4.2.3 SAFETY BELT**

This is a two-point safety belt, as it is fixed in two points of the seat and holds the tractor driver over his waist.

At first, the safety belt is in setting position, which means that it must be set to correct length before first use, according to user's body.

Fasten the safety belt by inserting the head (fixing element) (1) in the buckle (2). Undo the safety belt by pressing the red button (3) on the buckle.

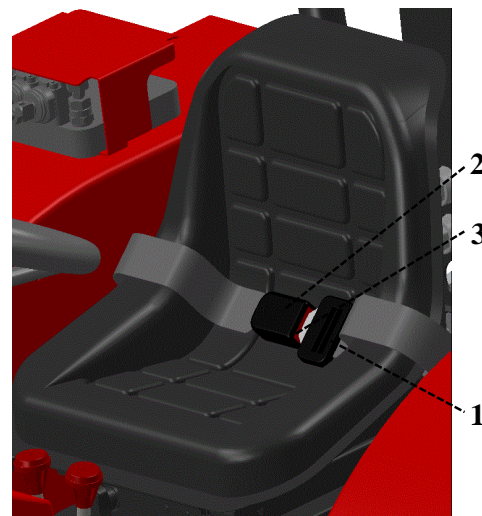

WARNING: When driving the tractor, always use safety belt, unless the roll bar is lowered!

4.2.4 PROTECTIVE COVER OF CARDAN DRIVE

Protective cover of cardan drive (1) prevents the operator to come into contact with rotating connection shaft (2).

Protective cover is manufactured in accordance with Directive 86/297/EEC.

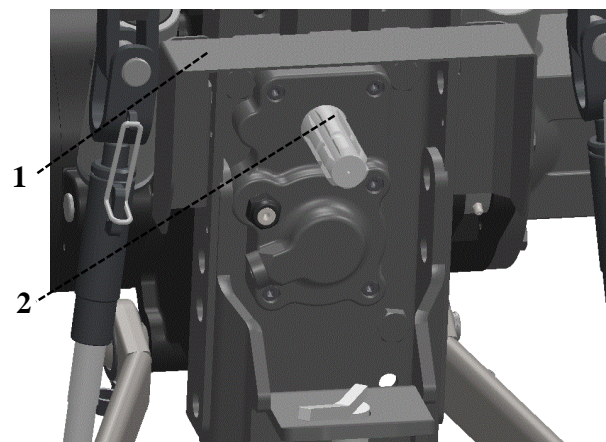

4.3 DRIVER'S SEAT

4.3.1 ACCESS TO DRIVER'S SEAT

- To climb into the tractor and exit it, always use the step and suitable gripping points.
- Access to driver's seat is possible from left or right.

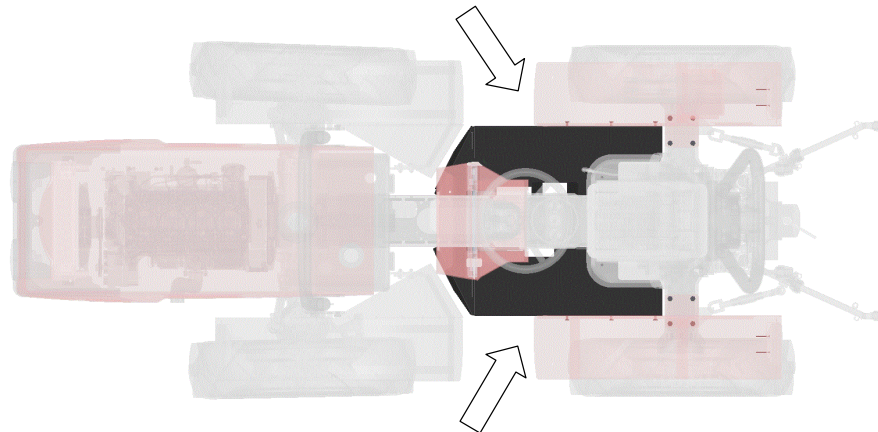

- Entry area and driver's seat must be clean, without any objects on them, which could interfere with further use.



WARNING: The seat can only be occupied by the driver or operator. Do not ascend or exit the tractor, if it is running!

4.3.2 DRIVER'S SEAT

Driver's seat with mechanic suspension is certified in accordance with Directive 78/764/EEC, including Directive 97/54/EC.

Shell form of the seat is designed to provide the user with good grip when driving on uneven or sloping ground.

Metal construction of the seat is protected against corrosion in accordance with quality standards of motor vehicle industry.

Because the seat has mechanical suspension with hydraulic shock absorber, it enables suitable comfort and protects the driver from excessive vibration.

Seat description:

- 1) Seat with polyurethane fill with black synthetic leather cover for easy washing;
- 2) Mechanical suspension with hydraulic absorber;
- 3) Two-point fixing safety belt;
- 4) Lever for setting hardness of hydraulic absorber;
- 5) Lever for setting seat height;
- 6) Lever for setting seat length.



Seat properties:

- Seat automatically adjusts to driver's weight (from 50 to 120 kg);
- Suspension system travel is 100 mm;
- Seat position can be set vertically up to 80 mm (height).
- Seat position can be set horizontally up to 150 mm (length).

4.4 DESCRIPTION OF HYDRAULICS

The main element of hydraulics, through which all hydraulic elements are supplied, is the hydraulic pump, which is connected directly to the engine and connects two independent systems:

- The first system supplies elements for lifting and, through control elements, additional distributors or implements.
- The second system supplies tractor steering and, through control block, performs differential lock and engaging of connection shaft (hydraulic clutch).

Hydraulic pump pumps oil from the rear part of transmission (gearbox housing) through filter into control elements.

Hydraulic control is consisted of:

1. **Control block;** its task is to engage and disengage the drive shaft (PTO) and block differential through electro-hydraulic valves;
2. **Hydraulic pump;** required pressure for operation of hydraulic system is supplied by two independent pumps:
 - a. Work pump for rear hydraulics (first system), capacity 11 cm³, with max. 31 l/min flow at 2800 rev./min., and pressure 230 bar.
 - b. Pump, connected to steering head (second system), capacity 8.5 cm³, with max. 24 l/min flow at 2800 rev./min., and pressure 230 bar.
3. **Steering cylinder or steering block;** intended for steering the tractor left or right;
4. **Four-way directional valve;** four-way directional valve automatically changes direction of operation of steering cylinder in opposite direction, when turning the seat for 180°.
5. **Cylinder housing;** together with belonging elements, blocks both, first and rear, differentials;
6. **Control elements;** intended for lifting or lowering rear hydraulics or activation of quick couplings (implements);
7. **Filter;** prevents oil particles to enter the pump and is installed on the suction line between the pump and gearbox housing;
8. **Connection shaft;** connection shaft is engaged by multiple disc clutch in oil bath, which is independent and separated from main clutch operation;
9. **Quick coupling (implement);** optionally, the tractor can be fitted with many quick couplings, at customer's request;
10. **Choke;** intended for soft start or prevents sudden thrust of connection shaft when activating solenoid valve. Choke operation is described in chapter "START CHOKE (SOFT START – PTO)".



IMPORTANT: Choke must always be open during operation!

4.4.1 HYDRAULIC SCHEME

1. Control block
2. Hydraulic pump
3. Steering head
4. Four-way direction valve
5. Cylinder housing
6. Control elements
7. Filter
8. Connection shaft
9. Quick coupling (implement)
10. Choke
11. Steering mechanism cylinder
12. Rear part of transmission (gearbox)

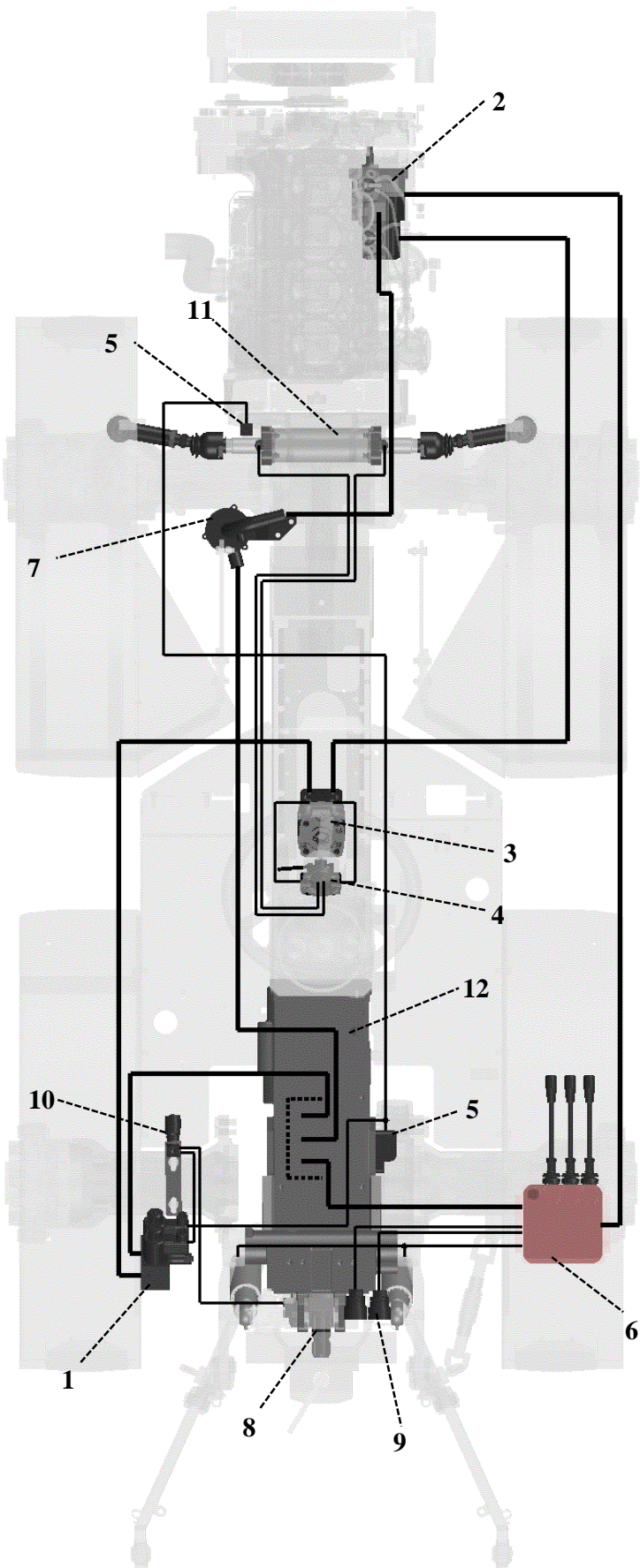

INSTRUCTIONS FOR USE

HYDRAULIC SCHEME

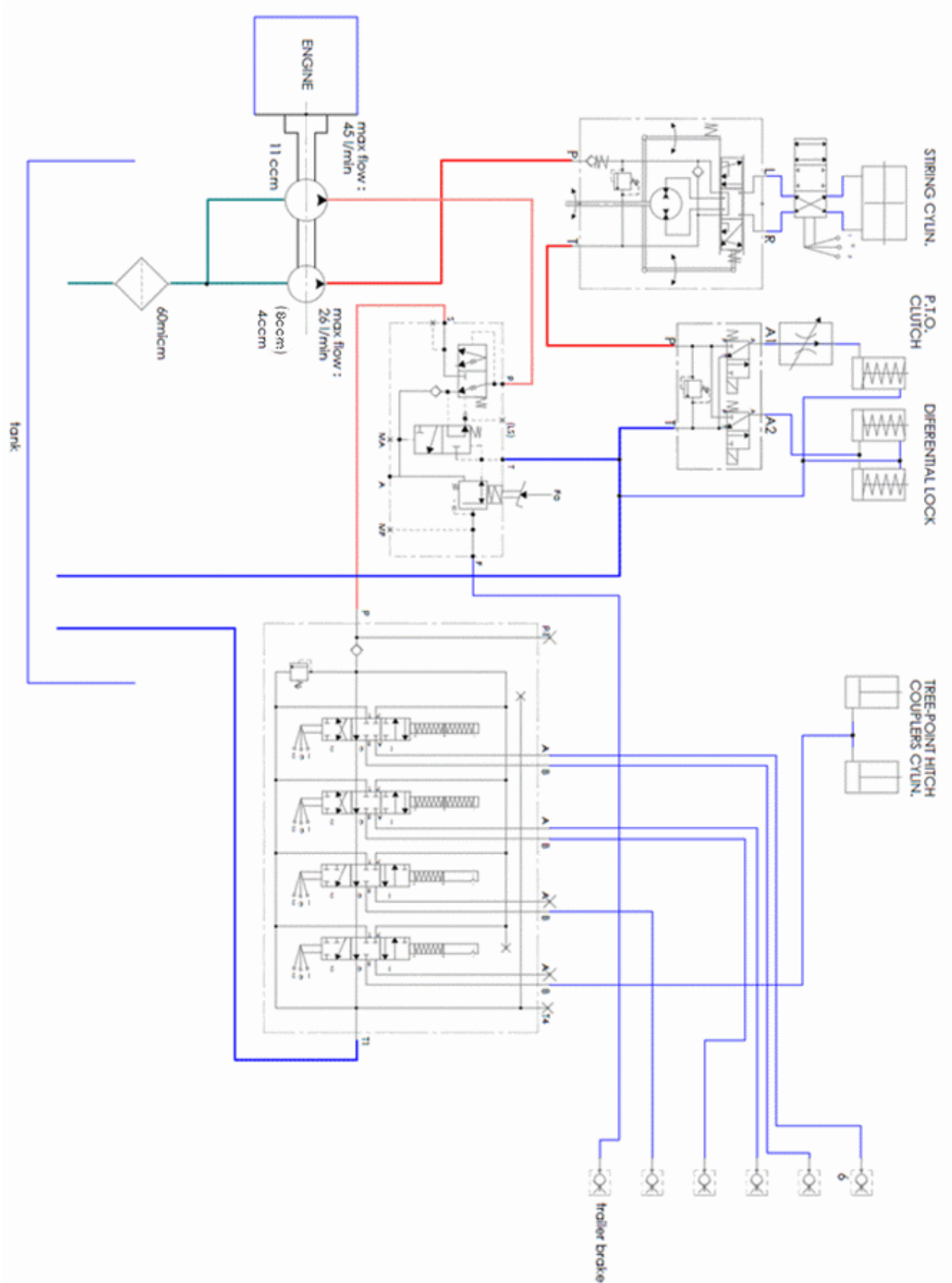

4.4.2 FRONT HYDRAULIC LIFT SYSTEM (OPTION)

The tractor can be, as option, equipped with front three-point lift mechanism, controlled by two one-way functioning hydraulic cylinders, and is fitted with connection for quick coupling for connection to hydraulic system of work implement.

Front three-point lift mechanism is controlled by control elements on the right side of the tractor, near the seat.

Work implement on three-point lift mechanism can be fastened in floating position and follows ground contour freely or is fastened rigid in certain position.

Description of main components:

1. **Hydraulic cylinder**; controls front three-point lift mechanism,
2. **Front connection arms**; enable connection of different types of implements,
3. **Top connection shaft (top link)**; enables connection to third point of implement,
4. **Safety frame**; protects engine cover, radiator and engine from possible damage, and also functions as resistance for connection of top connection shaft in third point of front lift mechanism,
5. **Front hydraulic connection**
6. **Pin**; enables simple and fast connection of work implement to front lift mechanism. On lower connection arms, two versions of pins are used, standard and pin with spring, which are described in detail in chapter "CONNECTING AND DISCONNECTING IMPLEMENT ON FRONT HYDRAULIC LIFT MECHANISM".

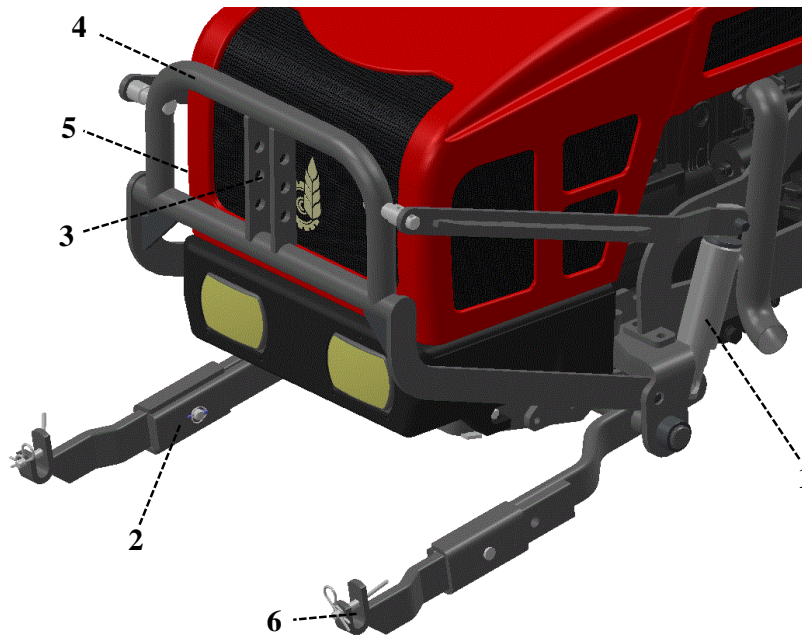

4.4.3 REAR HYDRAULIC LIFT MECHANISM

The tractor is, for towing implements, fitted, as standard, with category I three-point hitch. Three-point hitch is consisted of two lower connection arms and top connection shaft.

Lower connection arms, through adjustable lift shaft, connected to lift arms, which are controlled by two one-way functioning hydraulic cylinders.

Lower hydraulic arms also have two lateral tensioners on each side, which function as limiters of transverse movement of three-point hitch with lifted carried implements. As all component elements of three-point hitch are joint-fastened, this enables flexibility in all directions.

Description of main components:

1. **Hydraulic cylinder;** controls rear three-point lift mechanism,
2. **Lower connection arms;** enable connection of different types of implements,
3. **Top connection shaft (top link);** enables connection to third point of implement,
4. **Lift arms;** enable lifting or lowering three-point lift mechanism,
5. **Lateral tensioner;** limits horizontal movement of three-point lift mechanism,
6. **Lift shaft;** adjustable height and connects lift arms with lower connection arms,
7. **Rear hydraulic connection;** installed quick couplings for connection of work implement with hydraulics.

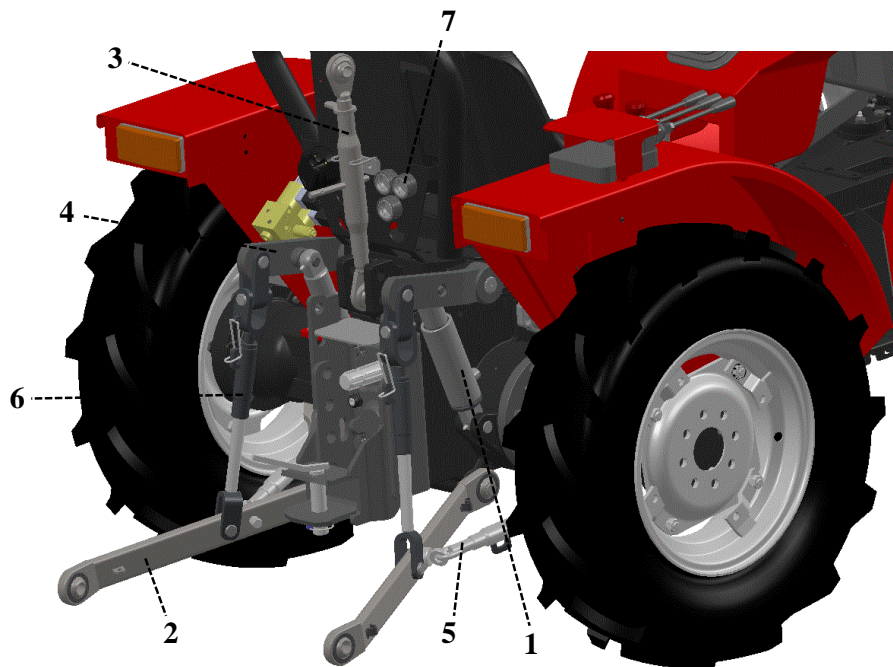

Two versions of connection are used on lower connection arms, which can then be divided to several options:

- **Connection with ball joint** is when the ball has standardized bore, in which a bolt is inserted, which is fitted on work implement, which we want to connect,
- **Ball connection (option)** is when balls with the same standardized bores are previously inserted on connection bolts of the machine, which we want to connect to the tractor. Lower connection arms of three-point hitch have a hook with ball dint at the end, which is fitted on the tractor. Connection is done by lifting front connection arms with accurate setting of the tractor with work implement.

INSTRUCTIONS FOR USE

Connection to top connection shaft can be done in two versions:

- mechanically adjustable with ball joint (standard) in which bolt is inserted or
- hydraulic with ball connection or joint (option)

Due to different size of tractors and work implements, three-point connection shafts are, as standard, divided into three categories.

Three-point connection shaft categories

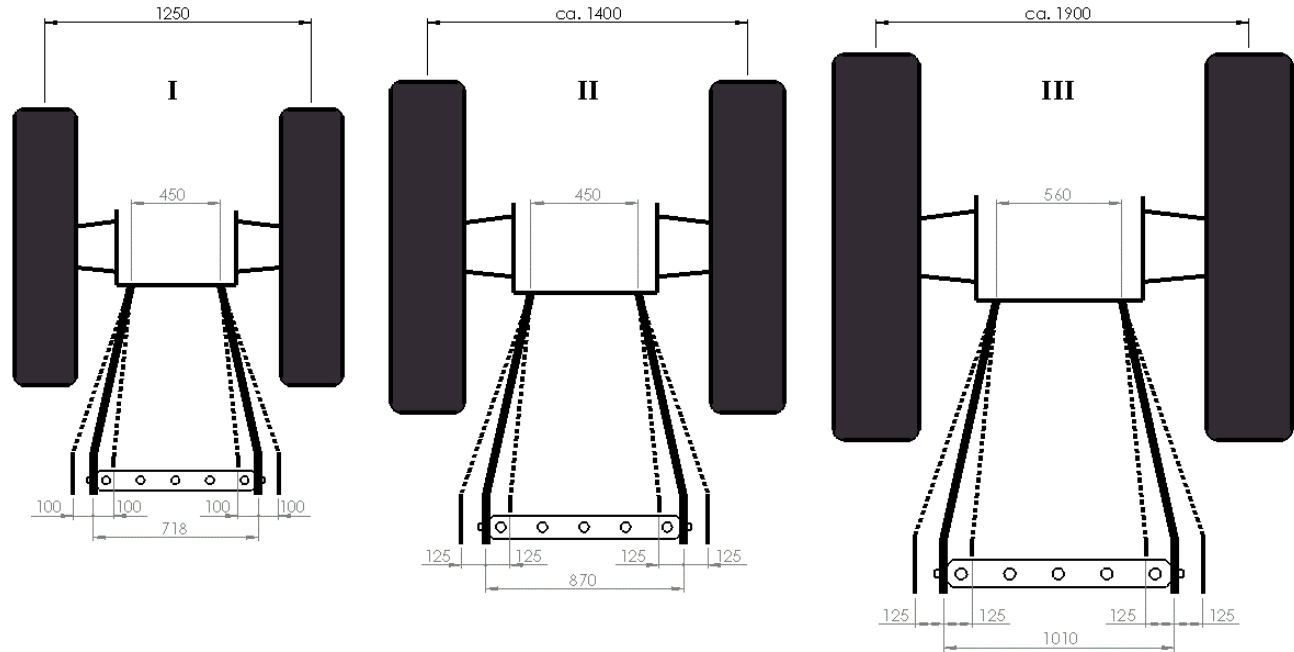

Tractor connection points – hole diameter for fixing pin	Lower connection shaft	Top connection shaft
	d4	d2
Category I	22.4	19
Category II	28.7	25.5
Category III	37.4	31.7

4.5 DESCRIPTION OF INSTRUMENTS AND CONTROL ELEMENTS

Chapter is divided in several categories for simpler description and easier understanding of all tractor control elements.

- Dashboard
 - Control elements
Detailed description is provided in "DESCRIPTION OF DASHBOARD CONTROL ELEMENTS".
 - Instruments and control lights
Detailed description is provided in "DESCRIPTION OF INSTRUMENTS".
- Controls for driving
Detailed description is provided in "DESCRIPTION OF CONTROL ELEMENTS FOR DRIVING".
- Controls for work
Detailed description is provided in "DESCRIPTION OF CONTROL ELEMENTS FOR WORK".
- Controls for hydraulics
Detailed description is provided in "DESCRIPTION OF CONTROL ELEMENTS FOR WORK".

4.5.1 DASHBOARD

Dashboard is divided into two parts – one part sends requested visual information to the driver of the tractor, and the other part is intended for various devices for control and required control of the driver of the tractor.

DESCRIPTION OF DASHBOARD CONTROL ELEMENTS



1. Switch for activation of direction indicators and high beam shutter

- To activate left direction indicator, move lever to the left in position A.
- To activate right direction indicator, move lever to the right in position B.

When direction indicators are activated, control light on the dashboard also flashes. To deactivate direction indicators, move the lever back to central position.

If you move the switch lever up in position C, you activate high beam shutter, and the lever returns to original position automatically.

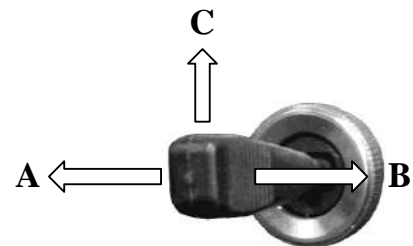

2. Rear connection shaft (PTO) switch

If you press the switch, you engage rear connection shaft (PTO). Control light on the switch is on. Press the switch again to disengage rear connection shaft.



Engaging rear connection shaft:

- In position 1, rear connection shaft (PTO) is disengaged (control light on the switch is off).
- In position 2, rear connection shaft (PTO) is engaged (control light on the switch is on).



3. Differential lock switch

Press the switch to activate differential lock. Control light on the switch turns on. Press the switch again to deactivate differential lock.



Activating differential lock

In position 1, differential lock of front and rear axle is deactivated (control light on the switch is off).

In position 2, differential lock of front and rear axle is activated (control light on the switch is on).



4. Main ignition switch

Activates electrical system and starts the tractor engine. Key can be turned to following positions:

0 – Deactivation of electrical system, you can remove the key

1 – Activation of electrical system. Warning lights for oil pressure in engine and electrical voltage turn on on the dashboard, as well as control light of glow plugs, which means that, in this position, also glow plugs in the engine begin to heat.

2 – Engine start, hold key in position 2 until it starts. When you release the key, it automatically returns to position 1.

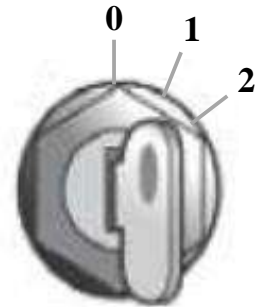

5. Switch for lights and sound signal (horn)

Rotate the switch to left and right to activate certain levels of light:

- In position 0, deactivated, lights are off.
- In position 1, position lights turn on and remain on even if the main ignition switch is turned off.
- In position 2, position lights turn on, but stay on only if the main ignition switch is turned on (key must be in position 1).
- In position 3, low beam lights turn on, but stay on only if the main ignition switch is turned on (key must be in position 1).
- In position 4, high beam lights turn on, but stay on only if the main ignition switch is turned on (key must be in position 1).

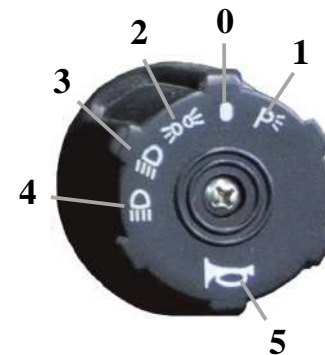

If you press switch (5), you activate sound signal (horn).

6. Hazard warning signal

If you press the switch, you activate a warning signal and all four direction indicators start blinking.



Activating hazard warning signal

- In position 1, hazard warning signal is deactivated (control light on the switch is off).
- In position 2, hazard warning signal is activated (control light on the switch is on).



INSTRUMENTS AND CONTROL LIGHTS



Control board

1. Instruments or indicators display current work status of the tractor
2. Control lights inform or warn about the work status of the tractor

INSTRUMENTS

Fuel gauge

Fuel tank capacity is 33 l.

Indicator on the gauge shows volume of remaining fuel in the tank. When the indicator moves to the red area, this means that there is only spare capacity of fuel remaining (less than 5 l), and a warning light turns on on the gauge.



	<p>WARNING: Do not leave the engine running, if the fuel tank is almost empty. If you interrupt the supply system due to lack of fuel, injection circuit must be bled!</p>
--	---

Cooling liquid temperature gauge

Gauge displays temperature of cooling liquid in the engine in range from 40 to 120 °C.

Work temperature of tractor engine is 85 °C.

Work areas:

- Blue zone – cold engine
- White zone – engine work temperature
- Red zone – engine overheating



When starting or if the engine is cold, the indicator is in the blue zone. At this time, do not overload the tractor and do not accelerate rapidly, but always wait for the engine to properly heat to work temperature (indicator in the white zone) before full load.

Engine overheats between 100 and 120 °C.



WARNING: If the indicator on the gauge moves in to the red area (red zone), immediately lower the load on the engine and leave it running in idle. When the temperature drops, shut down the engine and inspect the cooling system. In case of trouble, consult a qualified mechanic!

Tachometer

Tachometer displays engine revolutions in rev./min.
Complete range of tachometer scale is 40×100 revolutions.
Value of 30×100 revolutions is equal to 1000 rev. of PTO.
Under the tachometer scale is work hour counter, which functions only when the tractor engine is running.



CONTROL LIGHTS

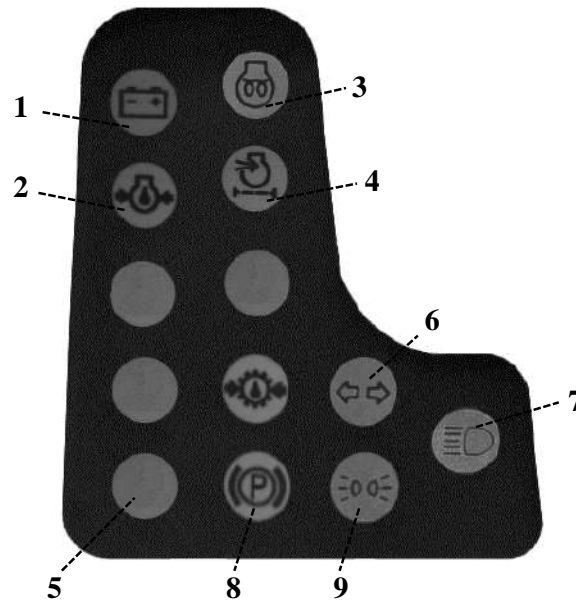

1. **Warning light for electrical voltage (red)**

Warning light turns on before engine start or when contact key is in position 1. After engine start or engine operation, the light turns off.

If the warning light for electrical voltage turns on after start or during engine operation, immediately turn off the engine, check the condition and tension of drive belt of alternator. If the belt is in good condition, the alternator could be faulty. Consult a qualified mechanic.

2. **Warning light for engine oil pressure (red)**

Warning light turns on before engine start or when contact key is in position 1. After engine start or engine operation, the light turns off.

If the warning light for engine oil pressure turns on, immediately turn off the engine and check oil level. If the oil level is under "min" mark, refill oil. If the warning light stays on or oil level drops again, consult a qualified mechanic.

3. **Control light for glow plugs (yellow)**

Control light turns on before engine start or when contact key is in position 1. Control light stays on for about 5 seconds, until glow plug reaches adequately high temperature for igniting mixture (oil) in engine cylinder. Glow plug is deactivated and the control light turns off. When the control light turns off, you can start the engine.

4. **Warning light for air filter (red)**

If the warning light is turned on, the air filter is clogged. In this case, the air filter or the inserts must be cleaned or replaced. Access the filter under engine cover (see chapter "MAINTENANCE").

5. **Warning light for hydraulic oil (red)**

If the warning light is turned on, the hydraulic oil filter is clogged. In this case, the oil filter must be replaced (see chapter "MAINTENANCE").

6. Control light for direction indicators (green)

If the control light is turned on, lateral left or right direction indicators, which are used to signal direction during driving, are turned on.

7. Control light for high beam lights (blue)

If the control light is turned on, high beam lights, intended for using the tractor at night with lower visibility, are on.

8. Control light for handbrake (red)

If the control light is turned on, handbrake is activated.

	<p>WARNING: Do not take off or drive the tractor with the handbrake activated!</p>
---	---

9. Control light for position and low beam lights (green)

If the control light is turned on, position lights, which illuminate the dashboard, and low beam lights, intended for tractor use, are on.

4.5.2 DESCRIPTION OF CONTROL ELEMENTS (CABIN)

Under the cabin roof is an installed ventilation device, which supplies fresh air into the cabin. Ventilation device can also heat air. Setting of air supply is controlled by the driver or user by using control elements, which are described further on.



1. Adjustable slots for internal air circulation

If the slots are closed, cold or warm air comes from under the roof only through supply slots and circulates in the cabin. If the slots are partially or fully open, air exits the cabin.

2. **Adjustable slots for air supply**

Slots enable supply of fresh air into the cabin through the fan. To change air flow direction, slots turn rotationally and adapt to driver or user needs.

3. **Internal cabin light**

Internal light illuminates driver's area in the cabin.

3.1 **Internal light switch**

Press the switch forward and backward to turn internal light on/off.

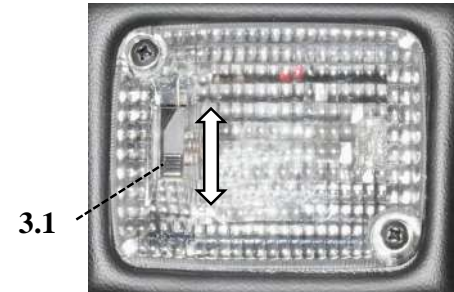

4. **Fan on/off switch**

Use the switch to set 3 speed levels of fan rotation.

5. **Temperature regulation switch**

Use the switch to set heating power in the tractor cabin.

6. **Wiper on/off switch, on front windshield.**

7. **Front work lights on/off switch**

8. **Rotation light on/off switch**

(optional, if a rotation light is installed on the tractor cabin)

9. **Rear work lights on/off switch**

10. **Wiper on/off switch, on rear windshield.**

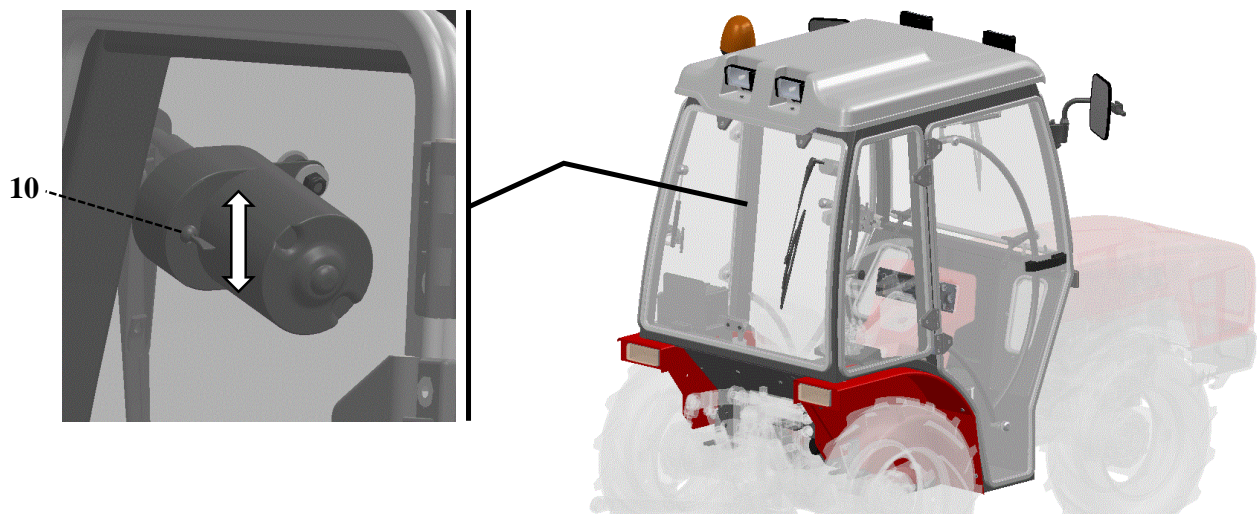

4.5.3 DESCRIPTION OF CONTROL ELEMENTS FOR DRIVING (PEDALS)

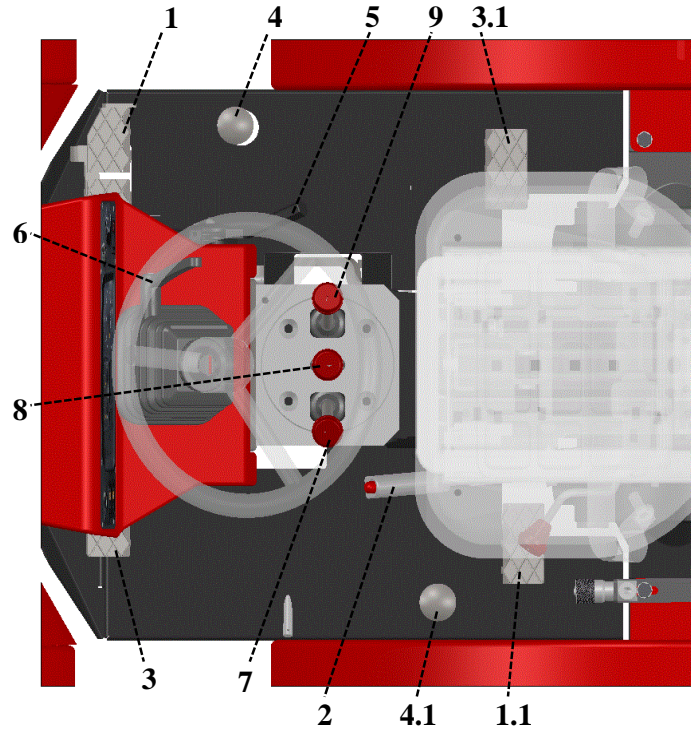

1. Foot brake

Two hydraulic disc brakes on rear drive shaft in oil bath, which are activated with two independent brake pedals.

A – brake pedal, braking of rear left wheel
B – brake pedal, braking of rear right wheel

Pedal can be connected with a pin (C), which, if connected, enables distributed tractor braking on all four wheels or, in case of separated pedals, independent braking of rear left wheel (A) or rear right wheel (B).

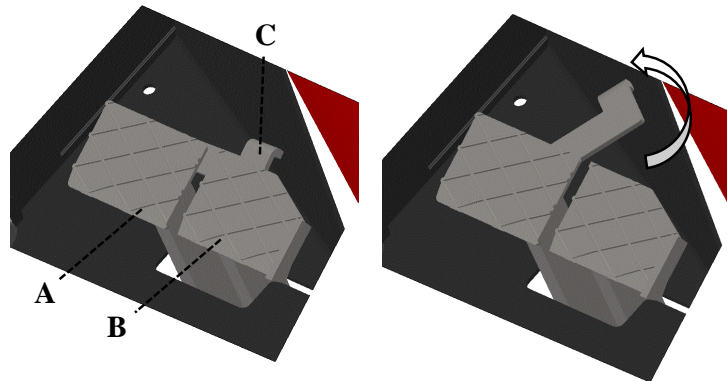

When the driver's seat is turned around, brake control function is performed with pedal 1.1.



WARNING: Separated pedals are intended exclusively for work with tractor. When driving on public roads, make sure that the brake pedals are connected!



WARNING: When driving uphill, both brake pedals must be connected!

2. Handbrake

Handbrake functions through lever completely independent of work brakes. It is intended mostly for blocking the wheels, when the tractor is stopped, when idling or when the tractor is completely stopped.

3. Clutch pedal

Clutch pedal controls the clutch when taking off and shifting. Clutch control is performed with pedal on the left side of the driver's seat. When the seat is turned around, clutch control function is performed by foot pedal 3.1.

When using the tractor, be careful of correct clutch pedal travel! (see chapter "SETTING CLUTCH PEDAL").

4. Throttle pedal

By using the throttle pedal, you change the number of revolutions of the tractor. If the seat is reversed, throttle control function is performed by throttle pedal 4.1.

5. Throttle lever

By moving the throttle lever (up and down) you can set the number of engine revolutions. When the throttle lever is fixed, it enables the driver to keep constant engine revolutions on the tractor.

Under the lever is a level scale, which shows the driver approximate value of load on the tractor engine. Greater area on the scale is the throttle lever, the greater the engine revolutions, the more it is under load and vice versa.



If the throttle lever is set on one point, with constant number of revolutions and you increase number of revolutions with throttle pedal, the number of revolutions increases until you keep the pedal depressed. When you step off the pedal, number of engine revolutions drops back to starting position, set by throttle lever.

6. Lever for setting steering wheel tilt

Lever enables setting tilt of the steering wheel to adjust it as best as possible to driver's ergonomics.

7. Lever for changing speed groups (reducer)

- Position "rabbit" activates fast transmission level
- Position "turtle" activates intermediate transmission level
- Position "snail" activates slow transmission level



8. Driving direction lever

Lever enables changing driving direction to forward or reverse.

- Position "arrow forward" means that the tractor is moving in the direction of driving
- Position "arrow backward" means that the tractor is moving in reverse



9. Gearshift lever

Numbers (1 to 4) mark transmission levels in the gearbox or tractor speeds. This means that driving with lever in level 1 is the slowest and in level 4 the fastest.



4.5.4 DESCRIPTION OF CONTROL ELEMENTS FOR WORK (CONNECTION SHAFT)

Reversible version of tractor (R)

Lever has function of selecting operation mode of connection shaft. For connection shaft operation, shift the lever (1) and turn on the switch to activate hydraulic multi disc clutch. Otherwise, the connection shaft does not work.

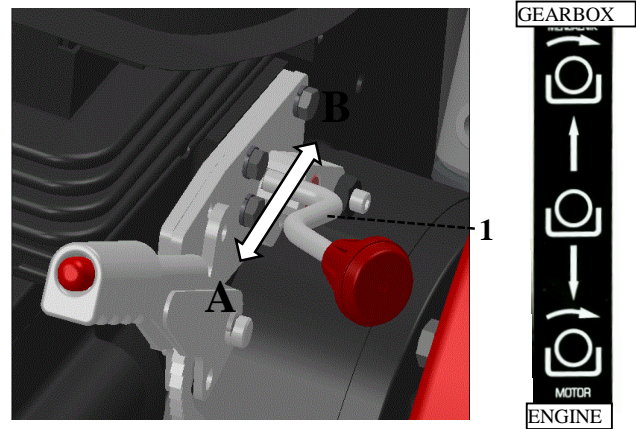

With lever (1) you can choose between two positions. **It is mandatory to use the clutch when shifting:**

- A.) Standard connection of connection shaft, directly to engine, move the connection shaft lever down. Connection shaft rotates in independent position, conditioned by number of engine revolutions (constant rotation to the right).
- B.) Synchronized type of connection of connection shaft to the gearbox, move the connection shaft lever up. Connection shaft rotates according to set gearbox ratio, left or right, depending on driving direction.

Connection shaft, connected to gearbox, functions only when the tractor is moving!

Irreversible version of tractor (NR)

In irreversible version of tractor (NR), the connection shaft is not controlled by switch. It is controlled mechanically with lever connection (2).

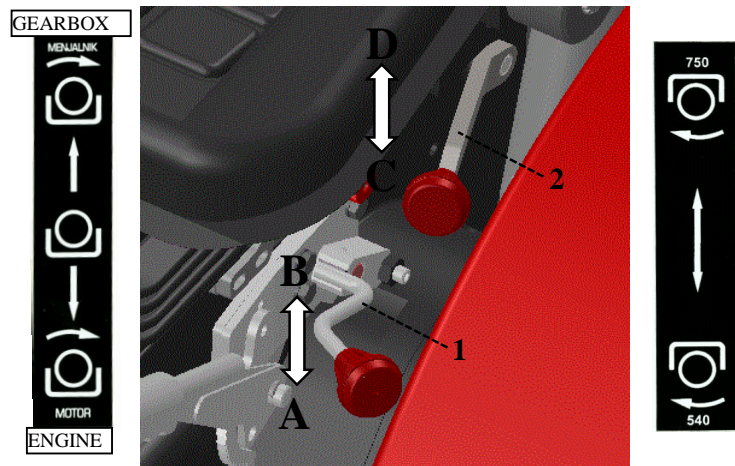

Use the lever (2) to select between two speed levels (C – 540, D – 750 revolutions), according to:

- A.) Standard connection of connection shaft, directly to engine, when you move the lever (1) down. Connection shaft rotates according to number of engine revolutions and selected speed level on the lever (2).
- B.) Synchronized type of connection of connection shaft to the gearbox, when you move the lever (1) up. Connection shaft rotates according to set gear ratio in gearbox and selected speed level on the lever (2).

It is mandatory to use the clutch when shifting!

	<p>WARNING: If you are not using the connection shaft, keep the lever in neutral position!</p>
--	---

Information for rotation speed of connection shaft are provided in chapter "TECHNICAL DATA – CONNECTION SHAFT").

4.5.5 DESCRIPTION OF CONTROL ELEMENTS FOR HYDRAULICS

Control element is a steering unit with control levers, with which we direct oil flow from tractor's pressure circuit to hydraulic outputs of internal or external hydraulic users.

Tractors are, as standard, equipped with control element with three control levers. If the tractor has, as option, an added front hydraulic lift mechanism, control element with four control levers is installed. Each lever performs certain function through control valve.

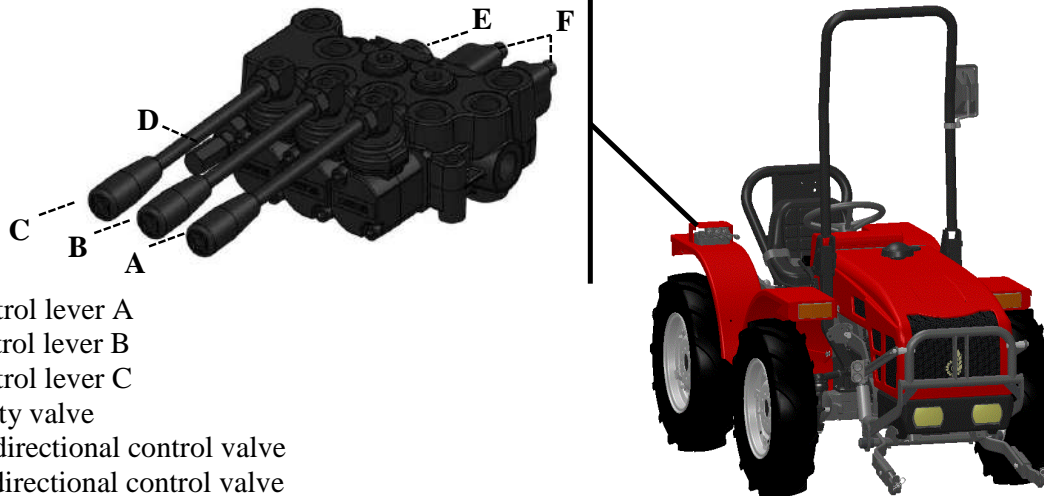

- A – Control lever A
- B – Control lever B
- C – Control lever C
- D – Safety valve
- E – 6/3-directional control valve
- F – 5/3-directional control valve

CONTROL VALVES

Control valves control oil flow from pressure line to a certain implement. There are three types of control valves: ONE-WAY, TWO-WAY or ONE-/TWO-WAY.

One-way functioning 5/3-directional control valve

One-way functioning control valve is connected only to one hydraulic conductor per implement, where the conductor is for pressure and return line (when the valve lever is in position 2 "reverse").

Control lever has three position:

- Position "1" – supply of oil under pressure (lift), control lever returns to neutral position automatically
- Position "0" – neutral position
- Position "2" – oil discharge (float position), control lever is stuck – manual shift into neutral position required

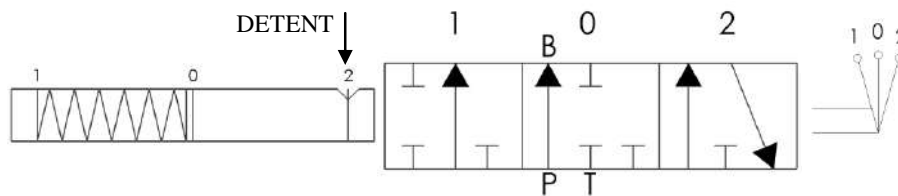

Stop device (DETENT)

Mechanically shuts active control valve, if you push the control lever to the end in certain direction. Valve can return (release in neutral position) only manually with control lever. If the valve is not fitted with a stop device, it always returns to NEUTRAL position, when the operator releases the control lever.

Two-way functioning 6/3-directional control valve

Two-way functioning control valve is for control of implements with two-way functioning hydraulic cylinder.

Control lever has three positions:

- Position "1" – supply of oil under pressure, control lever returns to neutral position automatically
- Position "0" – neutral position
- Position "1" – supply of oil under pressure, control lever returns to neutral position automatically

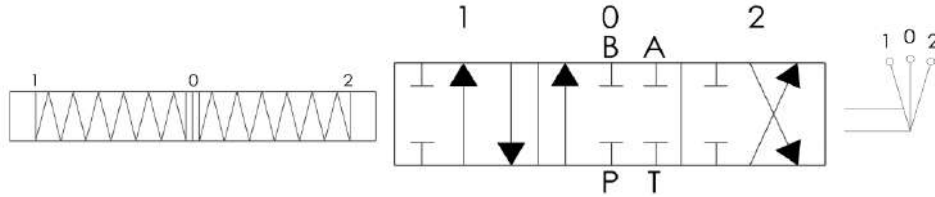

One-/two-way control valve

This valve is very similar to two-way functioning control valve, but in can be, with a special screw, transformed into one-way functioning control valve.

Standard tractor version is fitted with two one-way functioning 5/3-directional control valves:

- For control of rear hydraulic lift mechanism
- For control of implements with one-way functioning hydraulic cylinder

And one two-way functioning 6/3-directional control valve:

- For control of implements with two-way functioning hydraulic cylinder.

	<p>IMPORTANT: If the control valves are not being used, control levers must always be set to neutral position.</p>
--	---

CONTROL ELEMENT (THREE CONTROL LEVERS)

Below is a description of distribution of functions according to control levers.

CONTROL OF REAR HYDRAULIC LIFT MECHANISM (SINGLE)

Control lever A

Control lever redirects oil from pressure circuit through one-way functioning directional control valve, directly to both one-way functioning hydraulic cylinders simultaneously, to control rear hydraulic lift mechanism.

Operation:

- If you move the lever up to position 1, lift mechanism rises. When you release it, the lever on the control element automatically returns to neutral position 0, and the lift mechanism remains in this lift position.
- If you move the lever down to position 2, lift mechanism starts to lower. Even when you release it, the lever remains fixed in position 2. Therefore, you must always manually move it to position 0, if you want to cancel lowering of lift mechanism.

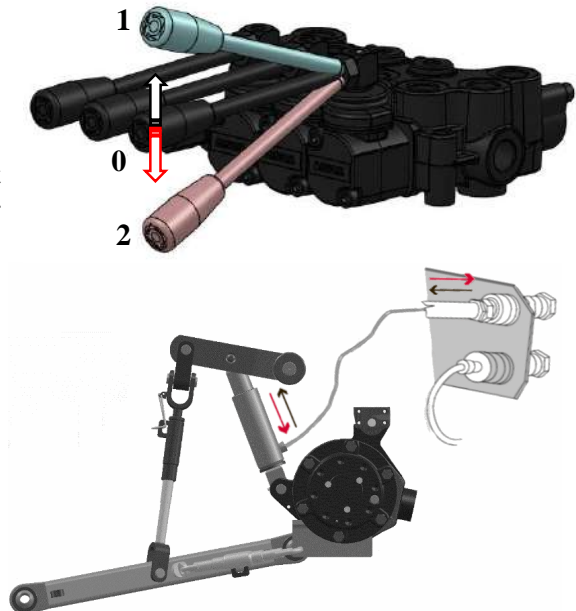

When the control lever is in position 2, and the lift mechanism is completely lowered, implement shifts to float position, so that it can adapt to the ground.

CONTROL OF HYDRAULICS THROUGH QUICK COUPLING (SINGLE)

Control lever B

Control lever redirects oil from pressure circuit through one-way functioning directional control valve through hydraulic output or quick coupling, for control of external hydraulic connections with one-way functioning hydraulic cylinder (e.g. implements with hydraulic system for tilting, such as dump trailers etc.).

This applies to standard tractor version, without installed front hydraulic lift mechanism. If the front hydraulic lift mechanism (option) is installed, control lever, in addition to redirecting oil through hydraulic output or quick coupling, also control the front hydraulic lift mechanism. This means that the control lever, in this hydraulic connection, individually controls function in the front or rear, depending on the connection on the quick coupling, for current work requirement of the user.

Operation:

- If you move the lever up to position 1, one-way functioning hydraulic cylinder on the implement is supplied with oil under pressure, and the hydraulic cylinder starts to rise. When you release it, the lever on the control element automatically returns to neutral position 0. Hydraulic cylinder remains on lift position.
- If you move the lever down to position 2, you release oil flow from one-way hydraulic cylinder back to hydraulic system of the tractor. Cylinder on the implement, with the help of external force or built-in spring (depending on version), starts to lower.

Control lever B, the same as control lever A, after release, remains fixed in position 2. Therefore, you must always shift it to position 0, if you wish to cancel lowering of hydraulic cylinder on the implement.

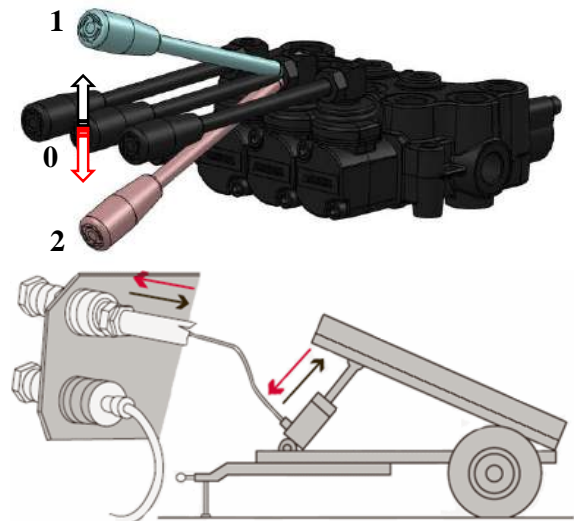

CONTROL OF HYDRAULICS THROUGH QUICK COUPLING (DOUBLE)

Control lever C

Control lever redirects oil from pressure circuit through two-way functioning directional control valve through hydraulic output or quick coupling, for control of external hydraulic connections with two-way functioning hydraulic cylinder.

Operation:

- When you move the control lever for operation of control valve into one of the positions (1 or 2), the piston in the valve moves in a way that oil from the pressure line flows only through one connection and from return through other connection and vice versa, if you shift the control lever in other direction.

When you release it, the lever on the control element automatically returns back to neutral, regardless of previous position.

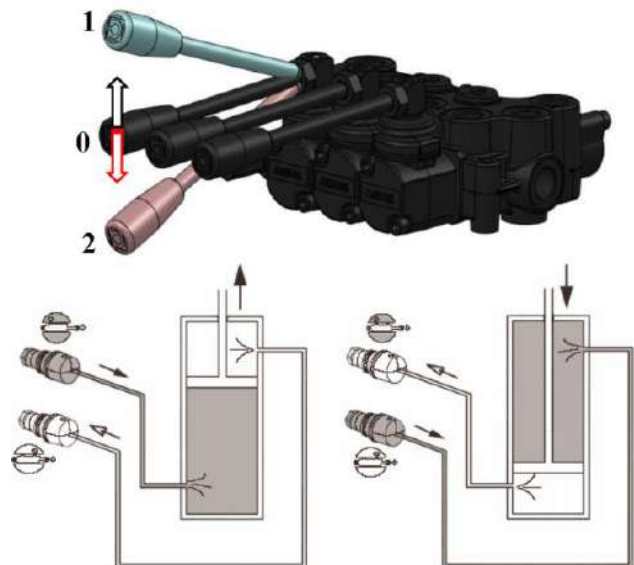

This applies to standard tractor version, without installed front hydraulic lift mechanism. If the front hydraulic lift mechanism (option) is installed, there are, in addition to two quick couplings on the rear, two other quick couplings on the front of the tractor. In this case, oil is supplied under pressure through control lever into both pairs of quick couplings simultaneously.

CONTROL ELEMENT (FOUR CONTROL LEVERS)

Control element with four levers is functionally controlled in the same manner as control element with three levers. The only difference is an additional control lever, which controls the front hydraulic lift mechanism completely independently from other functions. Below is a description of distribution of functions according to shift levers.

CONTROL OF REAR HYDRAULIC LIFT MECHANISM (SINGLE)

Control lever A

See description in the previous chapter for shift lever operation.

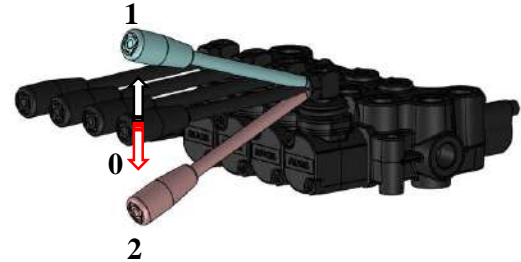

CONTROL OF FRONT HYDRAULIC LIFT MECHANISM (SINGLE)

Control lever B

Shift lever B functions the same as shift lever A. See description in the previous chapter for shift lever operation.



CONTROL OF HYDRAULICS THROUGH QUICK COUPLING (SINGLE)

Control lever C

See description in the previous chapter for shift lever operation.



CONTROL OF HYDRAULICS THROUGH QUICK COUPLING (DOUBLE)

Control lever D

See description in the previous chapter for shift lever operation.



4.6 OPTIONAL EQUIPMENT

This chapter describes optional equipment, which can be installed according to demands of the tractor user.

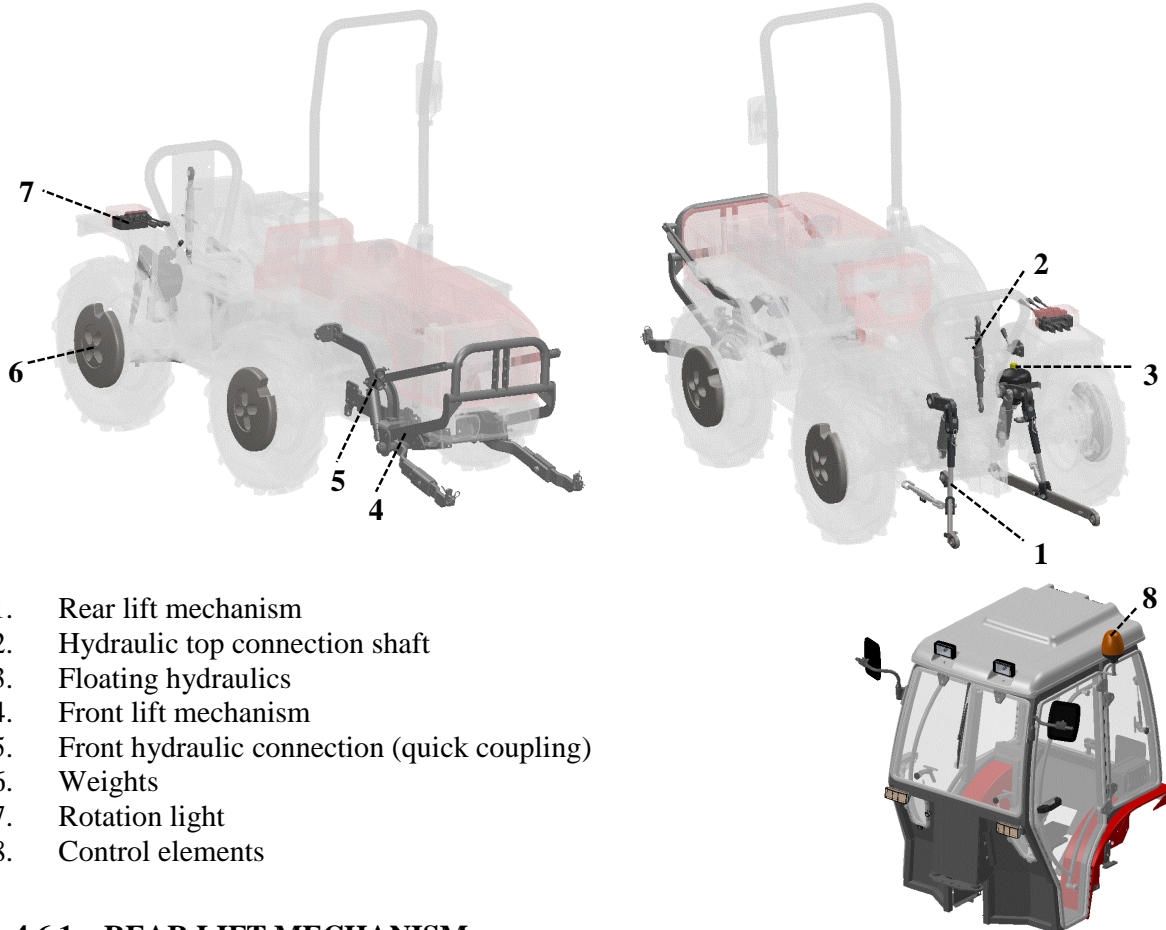

1. Rear lift mechanism
2. Hydraulic top connection shaft
3. Floating hydraulics
4. Front lift mechanism
5. Front hydraulic connection (quick coupling)
6. Weights
7. Rotation light
8. Control elements

4.6.1 REAR LIFT MECHANISM

Rear lift mechanism has several options of equipment, standard connection with ball joint and ball connection (quick connection).

Standard connection (with ball joint)

Rear lift mechanism with standard connection is available in two versions:

- Standard connection with ball joint on lower connection arms (rigid)

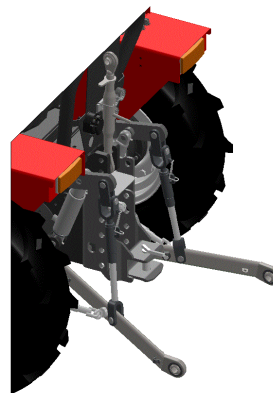

- Standard connection with ball joint on lower connection arms (arms have adjustable length)

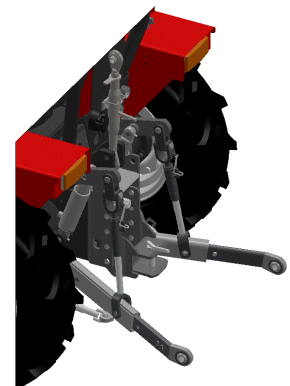

Ball connection (quick connection)

Rear lift mechanism with ball connection on lower connection arms of three point type and enables quicker connections to different types of implements.

Mechanism with ball connection is, as option, available in several versions:

- Ball connection on lower connection arms (rigid)

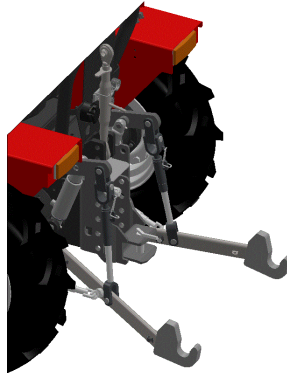

- Ball connection on lower connection arms (arms have adjustable length)

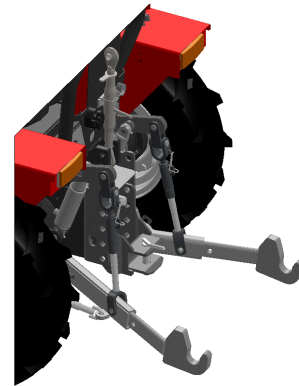

- Ball connection on fixed fastened connection arms (arms have adjustable length, ball connection moves only horizontally on arms)

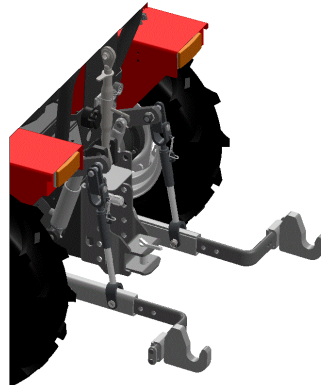

Rear lift mechanism is available with different lift shafts and top connection shafts (top links)

1 Standard lift shaft

As standard, there are two lift shafts fitted on the hydraulic lift mechanism, on the left and right side.

2 Hydraulic lift shaft

Hydraulic lift shaft is fitted only on one side, the right side of hydraulic lift mechanism.

Hydraulic lift shaft enables adjustment of lower connection arms through shift lever, directly from the driver's seat.

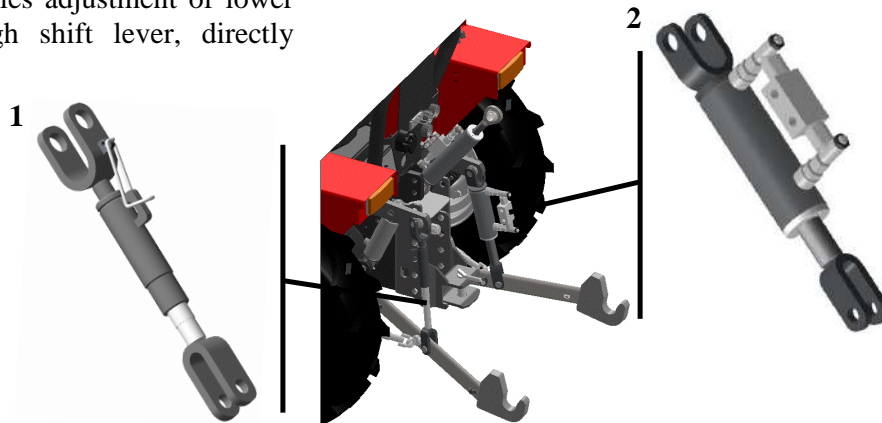

- 1 **Standard (mechanic) top connection shaft**
- 2 **Hydraulic top connection shaft (top link)**

Enables hydraulic adjustment of top connection shaft or crossbar for connection on third point of implement through shift lever, directly from the driver's seat.

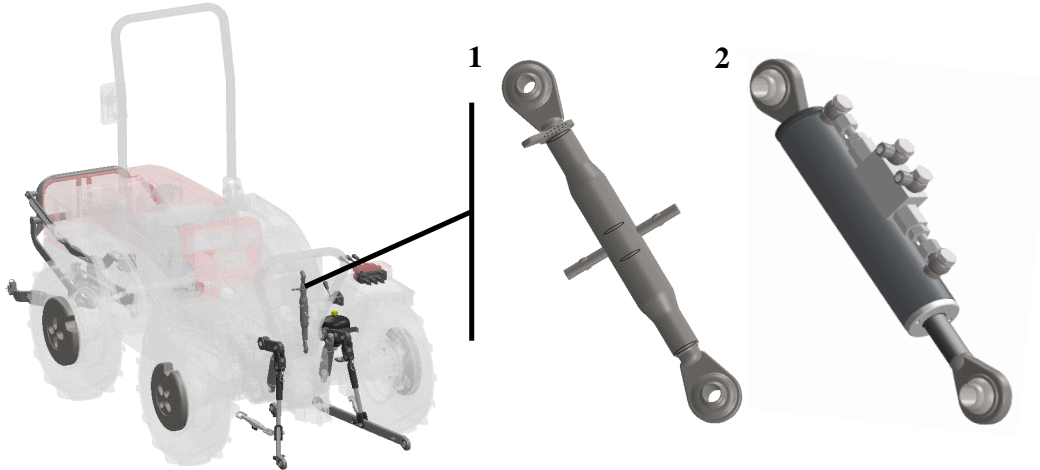

4.6.2 FRONT LIFT MECHANISM

Front lift mechanism is of three point type with adjustable lower connection arms. As option, mechanism can have two different types of pins on lower connection arms:

Standard pin – lower connection arms with fitted implement, fixed manually with bolt and pin.



Quick pin – with mechanism, lower connection arms are, with fitted implement, automatically fixed by a spring.

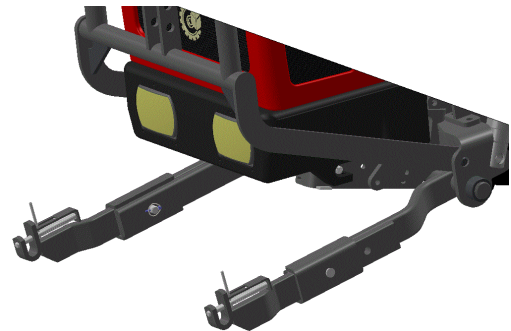

4.6.3 FRONT HYDRAULIC CONNECTION

Front hydraulic connection has quick couplings, which are intended for connection of work implement with hydraulics.

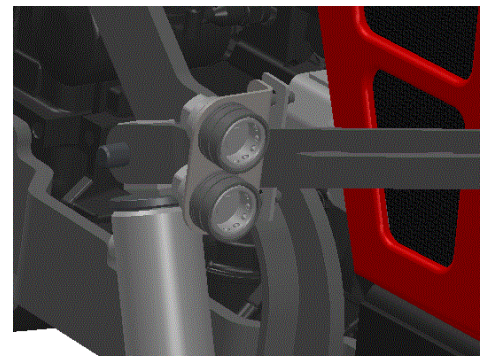

4.6.4 WHEEL DIMENSIONS

The tractor can be, as option, fitted with wheels of different dimensions. Basic dimensions are described further on, but there is also option of adjusting rims for track width.

- Adjustable rims (5.5x16, W8x16, W8x18, W9x18). To set track with adjustable rims, see chapter Technical data.
- Fixed rims (13LBx15, 9x15)

4.6.5 WHEEL EXTENSIONS

Wheel extensions are intended for additional widening of tractor wheelbase. **Length of each extension is 80 mm.** As option, user can choose between two extension types, with different hole positioning (four or eight) and with or without internal thread for short or long screws, depending on tractor version.

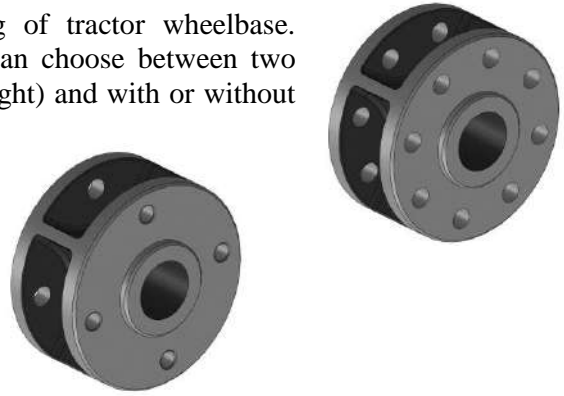

4.6.6 WEIGHTS

Weights are intended to increase stability of the tractor, when work implements are fitted. For standard tractor version, two types of weights are used:

Wheel weights – are installed on all four wheels, front and rear, on exact defined points with four screws. As option, two versions of wheel weights are used, depending on dimensions of wheels, which are fitted on the tractor.

Wheel weight (40 kg), wheel dimensions:

- 5,5x16
- W8x16
- W8x18
- W9x18



Wheel weight (50 kg), wheel dimensions:

- 13LBx15
- 9x15

Concrete weight of 340 kg is fitted on three-point hitch of rear hydraulic lift mechanism.

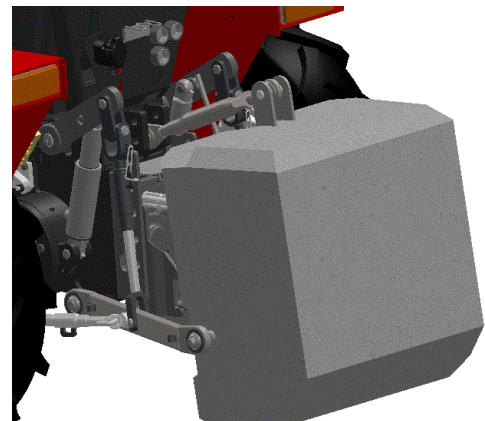

DANGER: During assembly and disassembly of wheel weights, be careful that your body parts do not get crushed!

4.6.7 ROTATION LIGHT

As option, tractor can be fitted with a rotation light (only with an installed cabin). On tractor with cabin, fitted with front lift mechanism, rotation light is fitted as standard.

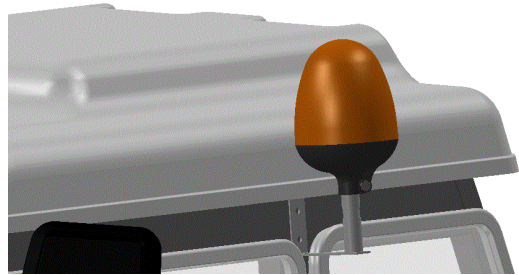

4.6.8 FLOATING HYDRAULICS WITH SUPPORT

The tractor can, as additional equipment, also be fitted with floating hydraulics or system for loading the tractor on surface and unburdening the weight of the implement on surface.

To engage floating hydraulics, lever of bottom valve (B) must be in position 2. If required during work, use control lever (A) for operation of control valve for lift of hydraulics to unburden (control lever in position 2) or load (control lever in position 1) rear axle of the tractor (see chapter "CONTROL OF REAR HYDRAULIC LIFT MECHANISM").

Charge the hydraulic battery with position for lift of control lever (position 1) for operation of control valve, as well as with own weight of implement when lowering.

Maximum allowable pressure is 180 bar.



IMPORTANT: If pressure changes for ~10 bar, force on the fixing axle of implement changes for ~750N (75 kg).

Discharge the hydraulic battery by moving the lever of lower valve (B) in position 2, then move control lever (A) in position 2 (lowering) and hold it, until the pressure gauge shows no pressure.

When you are not using the system, shut it down. Lever on the lower valve (B) must be in position 1, and there must be no pressure in the system!

For faster lift of hydraulics, you can move the lever of lower valve (B) to position 1.

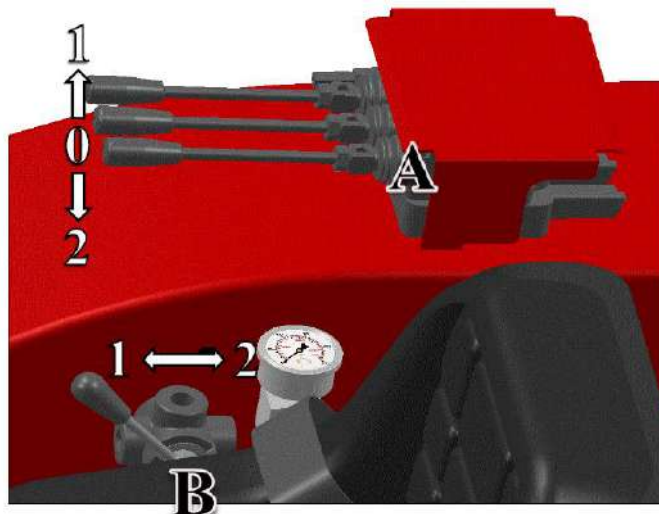

WARNING: Before interfering with the hydraulic system (connection/disconnection of implements), lever (B) must be in position 1, and there must be no pressure in the system!

HYDRAULIC SCHEME

LEGEND

1. Three-directional valve
2. Pressure gauge
3. Floating hydraulics battery
4. Hydraulic pump
5. Rear part of transmission (gearbox)
6. Control elements
7. Oil filter

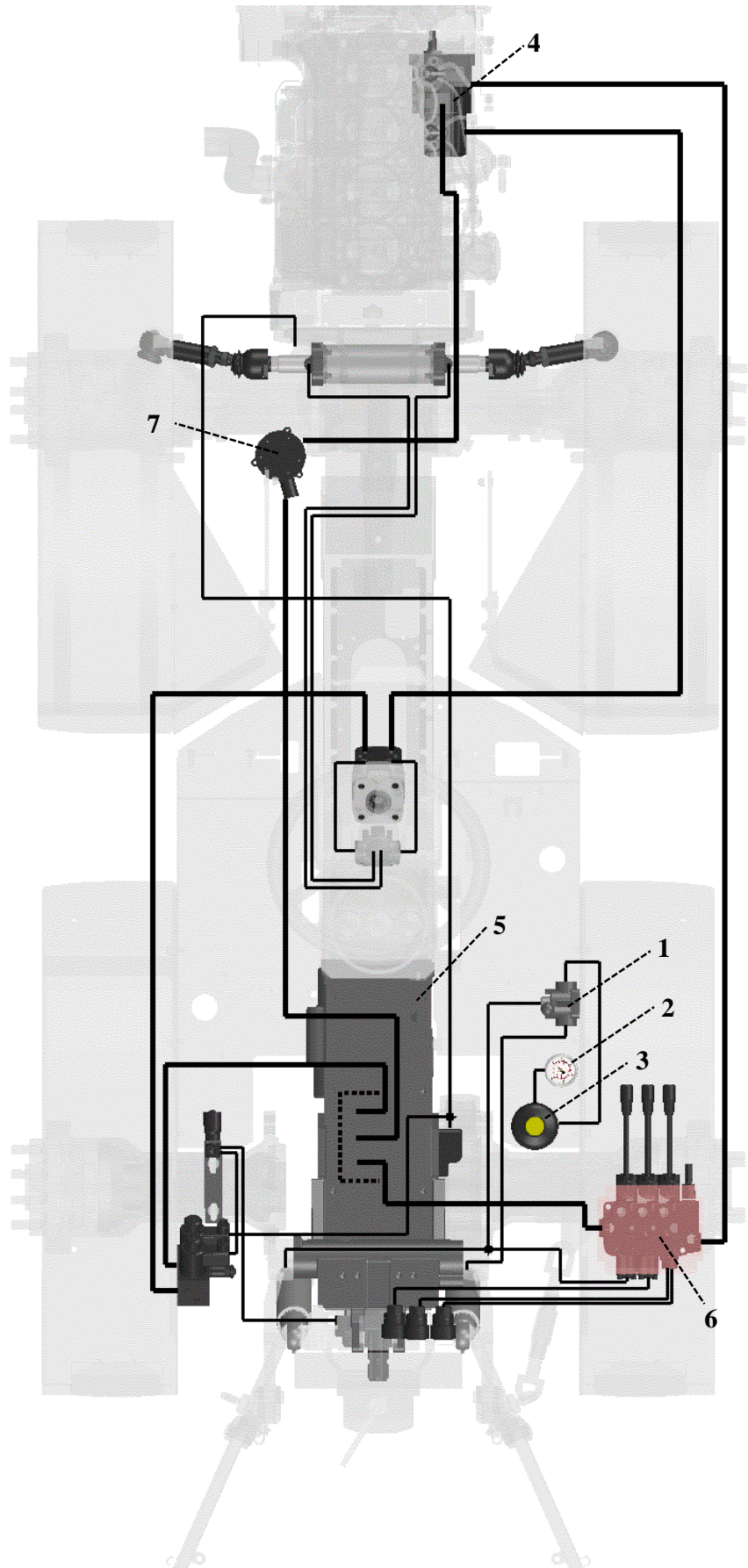

4.6.9 HYDRAULIC BRAKE OF TOWED IMPLEMENT

The tractor can be, as additional equipment, also fitted with system for connection of towed implements with hydraulic brake.

Operation

When pressing the brake pedal, wire rope activates lever on the brake valve mechanism for trailer. Brake valve redirects oil from pressure circuit through hydraulic conductor to brake system of towed implement and the implement begins to brake on its own.

Connection

Hydraulic coupling on the brake valve is male, $\frac{3}{8}$ " in dimension and enables connection of female connection tube.

To connect hydraulic connection tube:

- Shift the tractor to lowest gear;
- Shut down tractor engine (key must be in position 0);
- Insert hydraulic connection tube in hydraulic coupling of brake valve of trailer (1) on tractor;
- After installation, start tractor engine and check that the hydraulic system is functioning flawlessly;
- To balance pressure in hydraulic brake system of implement, depress brake pedal a few times.

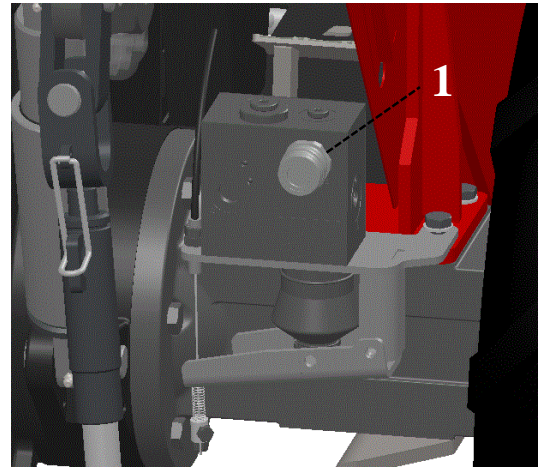

To disconnect hydraulic connection tube:

- Shut down tractor engine (key must be in position 0);
- Remove hydraulic connection tube (2). Press tube forward, pull safety (3) towards yourself to activate and release it, and pull the coupling back.

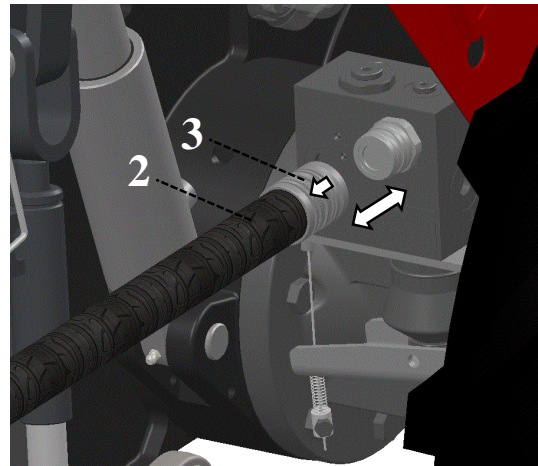



Maximum pressure at hydraulic coupling output is 80 bar!

Before interfering with hydraulic system, it is mandatory to unburden it. To do this, shut down the tractor and depress brake pedal a few times.

	<p>IMPORTANT: Before making connection, check that the system of towed implement corresponds to work pressure of tractor.</p>
---	--

	<p>WARNING: When disconnecting, it is obligatory to secure the towed implement with handbrake and safety wedges against moving!</p>
---	--

	<p>WARNING: Brake system of the tractor does not allow separate operation of foot and hand brake. Due to pressure in the pressure circuit of the tractor with activated brakes, connecting or disconnecting can be <u>performed only when the brake is not engaged!</u></p>
	<p>WARNING: Because the wire rope is connected only with one pedal, both brake pedals must be mechanically connected with a pin during driving!</p>

ADJUSTMENT OF WIRE ROPE

Before connection, you must check tension of wire rope. If it is overstrained, it must be set again. Wire rope can be adjusted in two positions – on the top part (fine adjustment) or on the bottom part (rough adjustment).

Fine adjustment

Follow the procedure below to perform the adjustment:

- Unscrew nuts (1 and 2);
- Adjust tension of wire rope. Turn bolt (3) to the right (clockwise) to loosen wire rope, and turn it to the left (counter clockwise) to tension it; hold the nut (1) during this procedure;
- Tighten nuts (1 and 2).

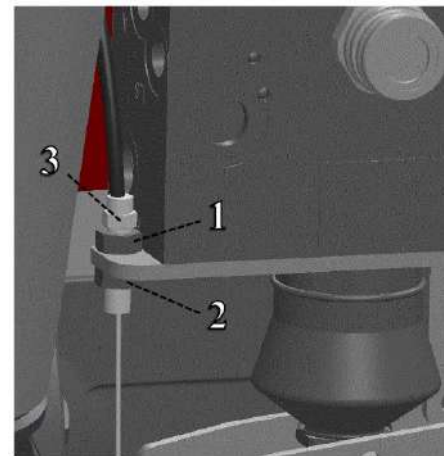

Rough adjustment

Follow the procedure below to perform the adjustment:

- Unscrew bolt (4 and 5);
- Move safety guide (6) to desired length;
- Tighten bolt (4 and 5).

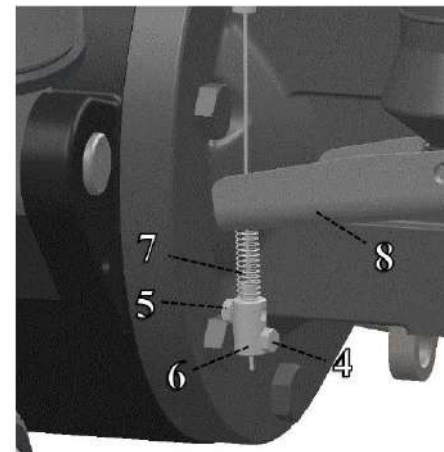

Correct tension of wire rope:

- When the spring (7) on the wire rope is not fully compressed, when the brake pedal is completely depressed;
- When there is certain minimal gap between spring (7) and lever (8), when the brake pedal is released.

	<p>WARNING: When the pedal is fully depressed, the spring must never be completely compressed!</p>
---	---

HYDRAULIC SCHEME

LEGEND

- 1. Quick coupling
- 2. Trailer brake valve
- 3. Brake valve battery
- 4. Hydraulic pump
- 5. Rear part of transmission (gearbox)
- 6. Control elements
- 7. Oil filter

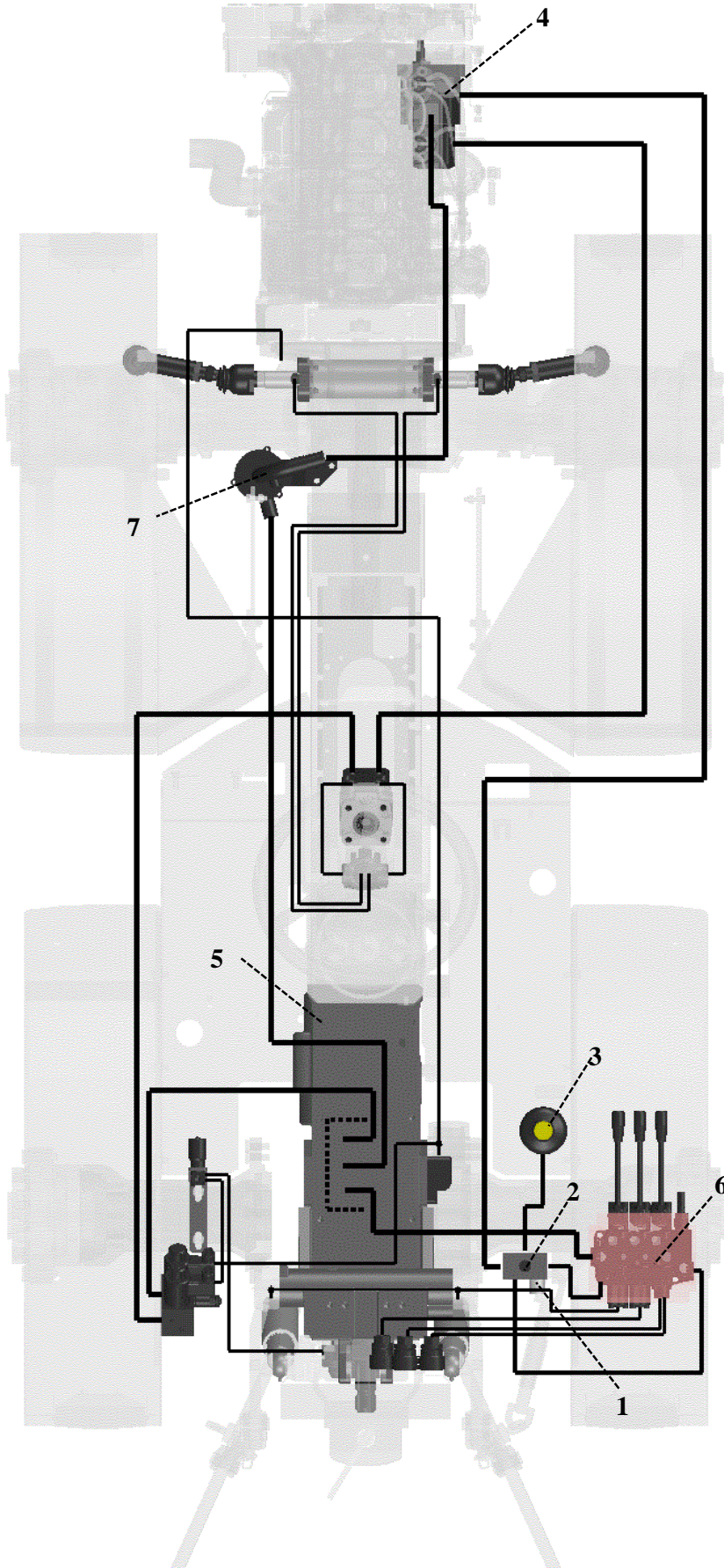

4.7 PREMIUM HYDRAULICS (OPTION)

Premium hydraulics is installed on the tractor as additional equipment. Due to large number of hydraulic functions, tractor enables the user with a wide spectre of use and is suitable for work in different fields.

Premium hydraulics, beside standard hydraulic control, is also consisted of:

1. **Control element (four control levers)**; intended for lifting/lowering front and rear hydraulic, lower connection arm or activating quick couplings (connections);
2. **Quick coupling (implements)**; with premium hydraulics, there are many quick couplings installed on the tractor for wide spectre of use;
3. **Choke**; intended for:
 - a. Soft start or prevention of sudden thrust of connection shaft when activating solenoid valve;
 - b. Regulation of speed of cylinder movement of rear hydraulic lift mechanism;
4. **Valve 3/2**; upon activation of solenoid valve, ensures soft start of connection shaft (control through PTO switch);
5. **Valve 2/2**; automatically activates upon connection of switch of rear connection shaft and differential lock. Its function is to supply oil to requested hydraulic components;
6. **Three-way directional valve**; transforms two-way functioning hydraulic cylinder into one-way or vice versa.

4.7.1 HYDRAULIC SCHEME

LEGEND

1. Control block
2. Hydraulic pump
3. Steering head
4. Four-way directional valve
5. Cylinder housing
6. Control elements (four control levers)
7. Control elements (three control levers)
8. Filter
9. Connection shaft
10. Quick coupling (implement – two-way operation)
- 10.1 Quick coupling (implement – two-way operation)
- 10.2 Quick coupling (implement – two-way operation)
- 10.3 Quick coupling (implement – two-way operation)
11. Quick coupling (implement – two-way operation)
12. Choke (PTO)
13. Choke (rear hydraulic cylinder)
14. Steering mechanism cylinder
15. Rear part of transmission (gearbox)
16. Solenoid valve 3/2 (soft start PTO)
17. Valve 2/2
18. Hydraulic cylinder (lifting/lowering lower connection arm)
19. Rear hydraulic cylinder (one-way or two-way option, lifting/lowering rear lift mechanism)
20. Three-way directional valve (turn for 45°, one-way or two-way operation of rear hydraulic cylinder)

HYDRAULIC SCHEME

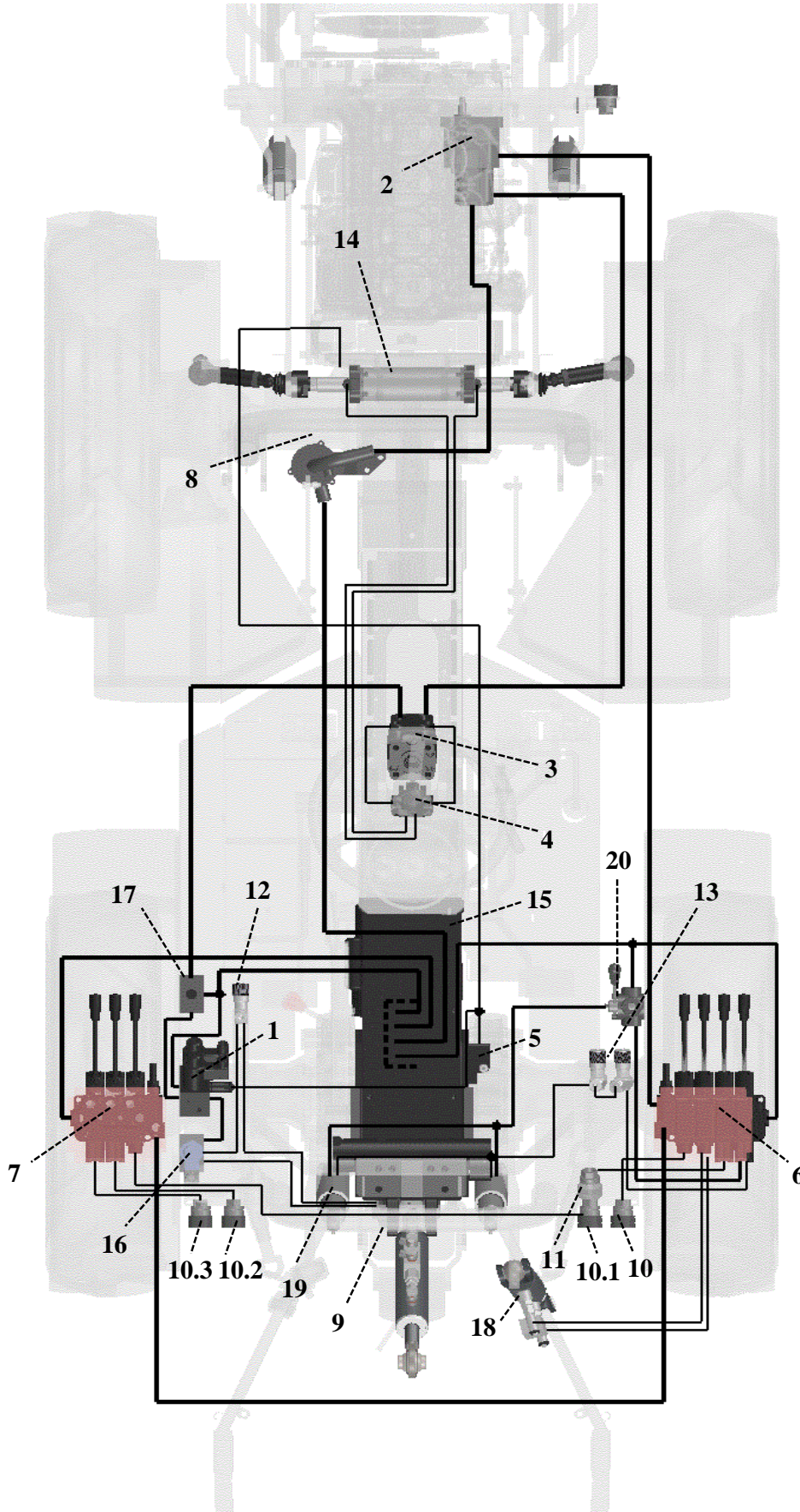

HYDRAULIC SCHEME

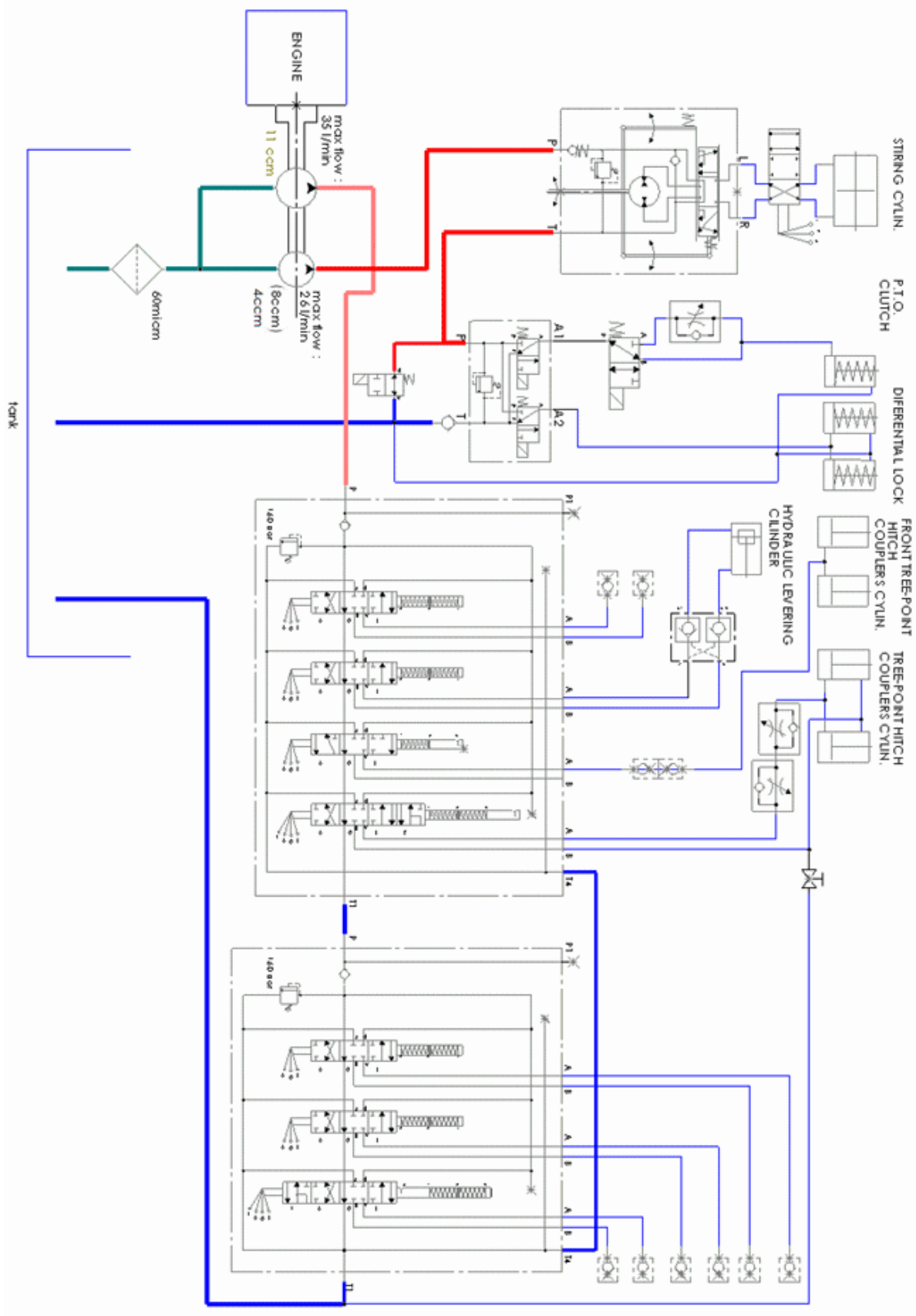

4.7.2 DESCRIPTION OF CONTROL ELEMENTS FOR HYDRAULICS

Control element is a steering unit with control levers, with which we direct oil flow from tractor's pressure circuit to hydraulic outputs of internal or external hydraulic users.

The tractor is equipped with two control elements with three or four control levers. Each lever performs certain function through control valve.

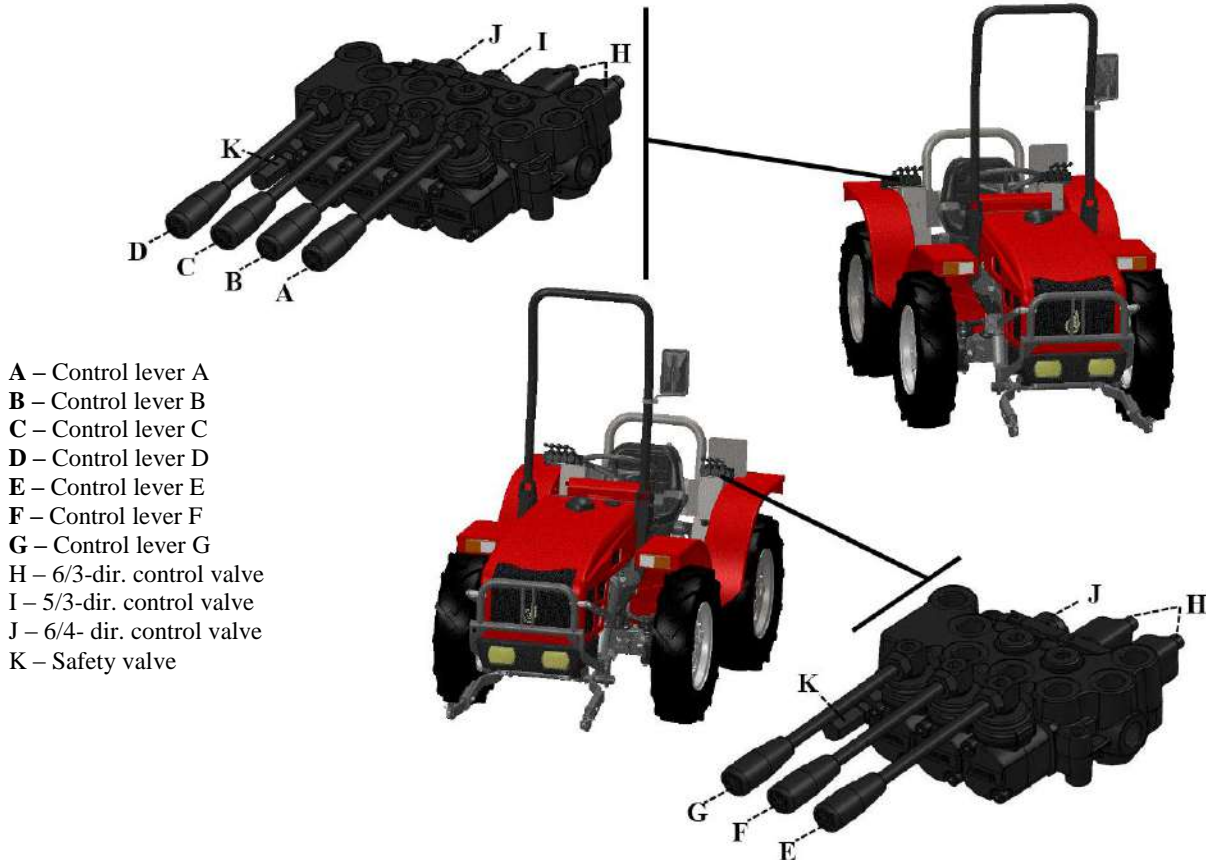

- A – Control lever A
- B – Control lever B
- C – Control lever C
- D – Control lever D
- E – Control lever E
- F – Control lever F
- G – Control lever G
- H – 6/3-dir. control valve
- I – 5/3-dir. control valve
- J – 6/4- dir. control valve
- K – Safety valve

4.7.3 CONTROL VALVES

Control valves regulate oil flow from pressure line to certain implement. There are two types of control valves – one-way and two-way.

One-way functioning 5/3-directional control valve (see chapter "DESCRIPTION OF CONTROL ELEMENTS FOR HYDRAULICS – CONTROL VALVES")

Two-way functioning 6/3-directional control valve (see chapter "DESCRIPTION OF CONTROL ELEMENTS FOR HYDRAULICS – CONTROL VALVES")

Two-way functioning 6/4-directional control valve

Two-way functioning control valve is used for regulating implements with two-way functioning hydraulic cylinder.

Version A (NS7)

Control lever has four positions:

- Position "1" – supply of oil under pressure, control lever returns to neutral position automatically
- Position "0" – neutral position
- Position "2" – supply of oil under pressure, control lever returns to neutral position automatically
- Position "3" – oil discharge (float position), control lever is fixed (detent) – required manual shifting to neutral position

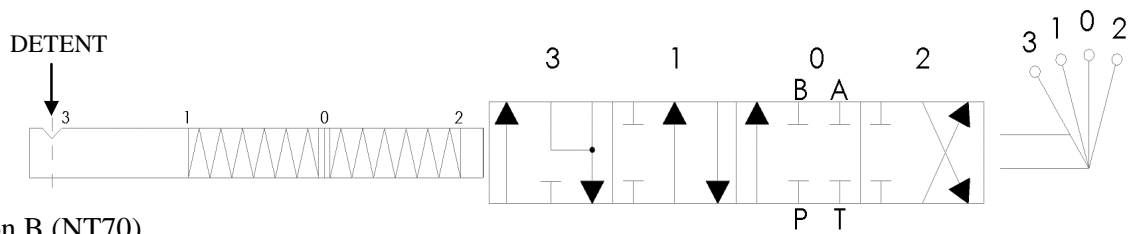

Version B (NT70)

Control lever has four positions:

- Position "1" – supply of oil under pressure, control lever returns to neutral position automatically
- Position "0" – neutral position
- Position "2" – supply of oil under pressure, control lever returns to neutral position automatically
- Position "4" – oil discharge (float position), control lever is fixed (detent) – required manual shifting to neutral position

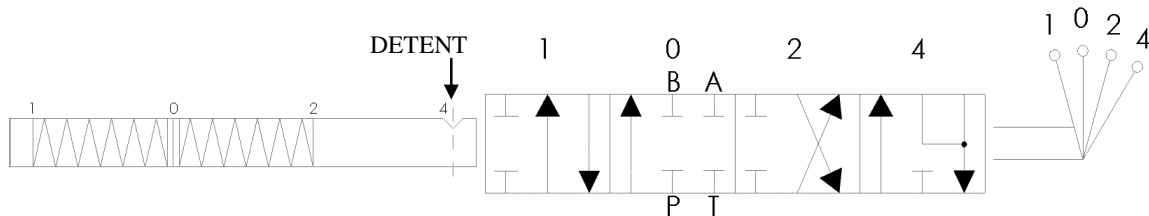

	IMPORTANT: When you are not using control valves, control levers must always be in neutral position.
--	---

4.7.4 POSITIONING OF CONTROL VALVES

Control element with three control levers has the following control valves installed:

- levers 1 and 2 regulate two two-way functioning 6/3-directional control valves for control of implements with two-way functioning hydraulic cylinder
- lever 3 regulates one two-way functioning 6/4-directional control valve version A for control of implements with two-way functioning hydraulic cylinder

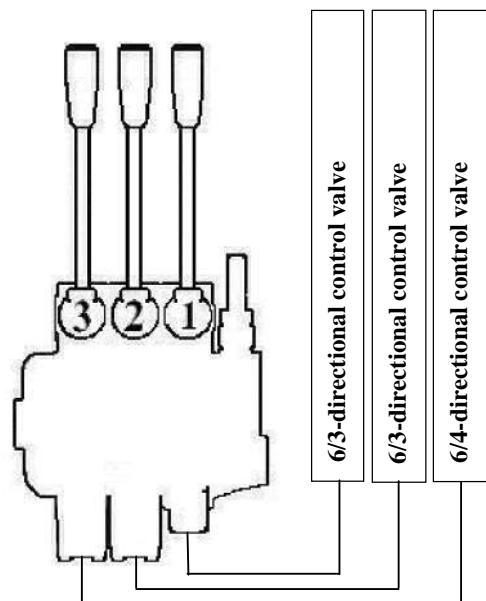

Control element with four control levers has the following control valves installed:

- levers 1 and 2 regulate two two-way functioning 6/3-directional control valves, one for control of implement with two-way functioning cylinder and one for control of two-way hydraulic cylinder for control of lower connection arms
- lever 3 controls one one-way functioning 5/3-directional control valve for control of implements with one-way hydraulic cylinder (standard for connection and control of front hydraulic lift mechanism)

- lever 4 control one two-way functioning 6/4-directional control valve version B for control of implements with two-way functioning hydraulic cylinder (standard for connection and control of rear hydraulic lift mechanism)

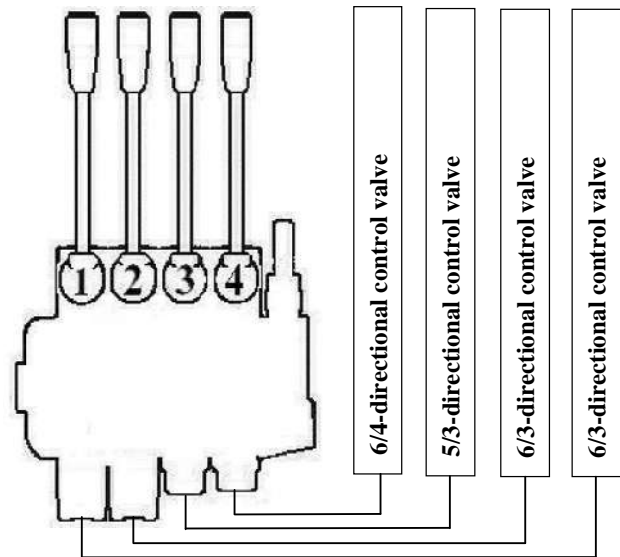

4.7.5 FUNCTIONING OF CONTROL ELEMENTS FOR HYDRAULICS

Basic distribution of functions, according to control levers, is described in the following.

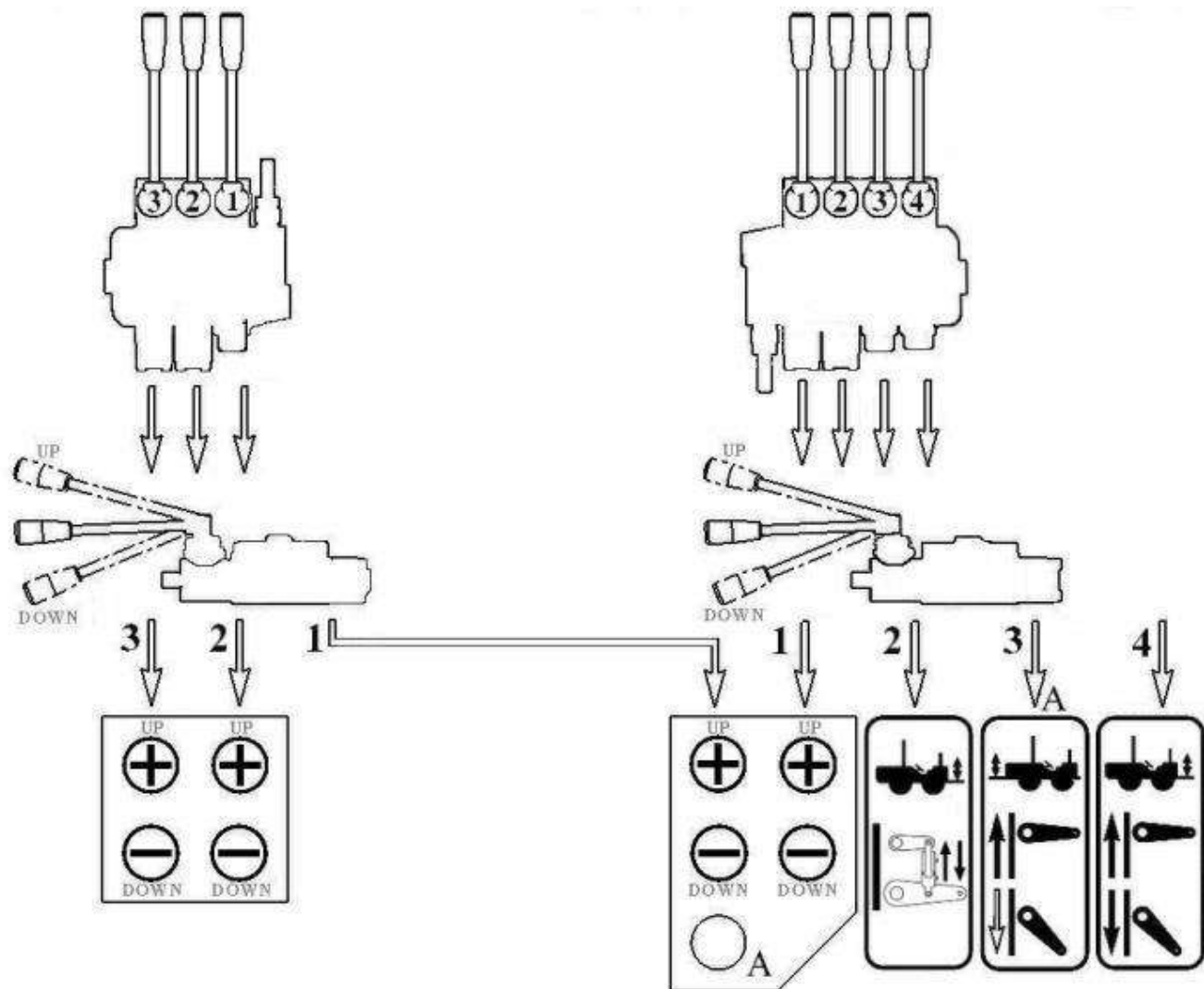

CONTROL ELEMENT (FOUR CONTROL LEVERS)

Distribution of functions, according to control levers, is described in the following.

CONTROL OF HYDRAULICS THROUGH QUICK COUPLING (DOUBLE)

Control lever A

Control lever redirects oil from pressure circuit through two-way functioning 6/3-directional control valve through hydraulic output or quick coupling, to control external hydraulic implements with two-way functioning hydraulic cylinder.

Operation:

- When you move the control lever for operation of control valve into one of the positions (1 or 2), the piston in the valve moves in a way that oil from the pressure line flows through one connection and from return through other connection and vice versa, if you shift the control lever in other direction. When you release it, the lever on the control element automatically returns back to neutral, regardless of previous position.

Control lever A

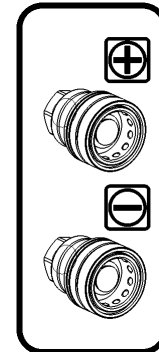
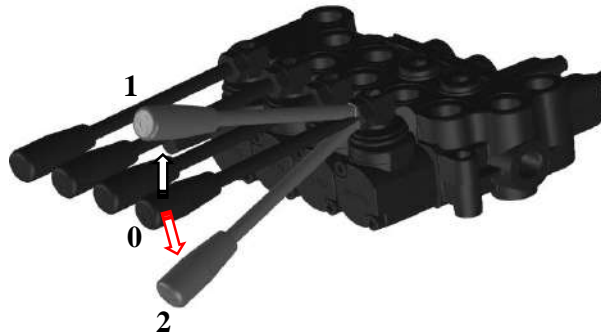
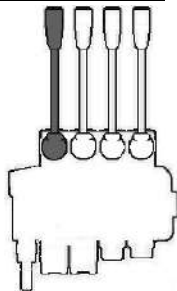

CONTROL OF HYDRAULIC CYLINDER FOR LIFTING/LOWERING LOWER CONNECTION ARM

Control lever B

Control lever redirects oil from pressure circuit through two-way functioning 6/3-directional control valve directly to hydraulic cylinder, to control lower connection arm.

Operation:

- When you move the control lever for operation of control valve into one of the positions (1 or 2), the piston in the valve moves in a way that oil from the pressure line flows through one connection on the cylinder (lifting) and from return through other connection and vice versa, if you shift the control lever in other direction (lowering). When you release it, the lever on the control element automatically returns back to neutral, regardless of previous position.

Control lever B

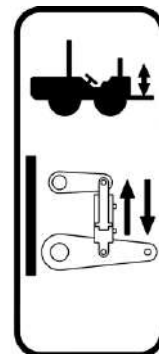
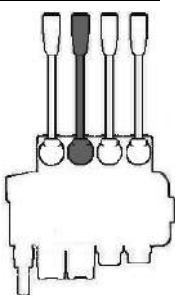

CONTROL OF FRONT HYDRAULIC LIFT MECHANISM

Control lever C

Control lever redirects oil from pressure circuit through one-way functioning 5/3-directional control valve through hydraulic output or quick coupling to both one-way functioning hydraulic cylinders simultaneously, to control external front hydraulic lift mechanism.

Operation:

- If you move the lever up to position 1, one-way functioning hydraulic cylinder on the implement is supplied with oil under pressure, and the hydraulic cylinder starts to rise. When you release it, the lever on the control element automatically returns to neutral position 0. Hydraulic cylinder remains on lift position.
- If you move the lever down to position 2, you release oil flow from one-way hydraulic cylinder back to hydraulic system of the tractor. Cylinder on the implement, with the help of external force or built-in spring (depending on version), starts to lower. Even when you release, the lever stays fixed in position 2 (DETENT). Therefore, you must always shift it to position 0, if you want to cancel lowering of lift mechanism.

Control lever C



CONTROL OF REAR HYDRAULIC LIFT MECHANISM

Control lever D

Control lever redirects oil from pressure circuit through two-way functioning 6/4-directional control valve (version B) directly to both two-way functioning hydraulic cylinders simultaneously, to control external rear hydraulic lift mechanism.

Operation:

- If you move the lever up to position 1, lift mechanism rises. When you release it, the lever on the control element automatically returns to neutral position 0, and the lift mechanism remains in this lift position.
- If you move the lever down to position 2, lift mechanism starts to lower. When you release it, the lever on the control element automatically returns to neutral position 0, and the lift mechanism remains in this lift position.
- As the control valve also functions as blocking device (DETENT), you can also move the lever to position 3. When you release it, the lever remains fixed in position 3. Therefore, you must always manually move it to position 0, if you want to cancel lowering mechanism.

When the control lever is in position 3, with completely lowered lift mechanism, implement shifts to float position, so that it can adapt to the ground.

Control lever D

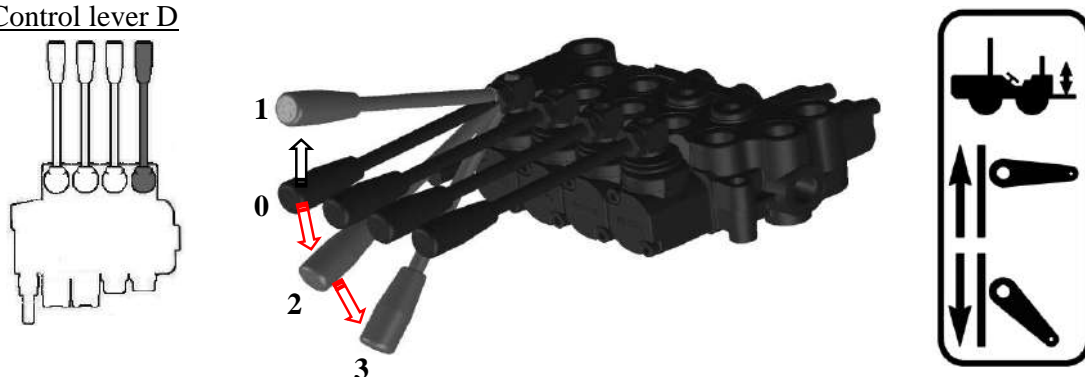

CONTROL ELEMENT (THREE CONTROL LEVERS)

Distribution of functions, according to control levers, is described in the following.

CONTROL OF HYDRAULICS THROUGH QUICK COUPLING (DOUBLE)

Control lever E

Control lever redirects oil from pressure circuit through two-way functioning 6/4-directional control valve (version A) directly to quick coupling, to control implement with two-way functioning hydraulic cylinder. As standard, quick couplings are already fitted with hydraulic top connection shaft or crossbar – top link, position of which can be changed by the user.

Operation:

- When you move the control lever for operation of control valve into one of the positions (1 or 2), the piston in the valve moves in a way that oil from the pressure line flows only through one connection and from return through other connection and vice versa, if you shift the control lever in other direction.

When you release it, the lever on the control element automatically returns back to neutral, regardless of previous position.

- As the control valve also functions as blocking device (DETENT), you can also move the lever to position 3. When you release it, the lever remains fixed in position 3. Therefore, you must always manually move it to position 0, if you want to stop oil supply.

Control lever E

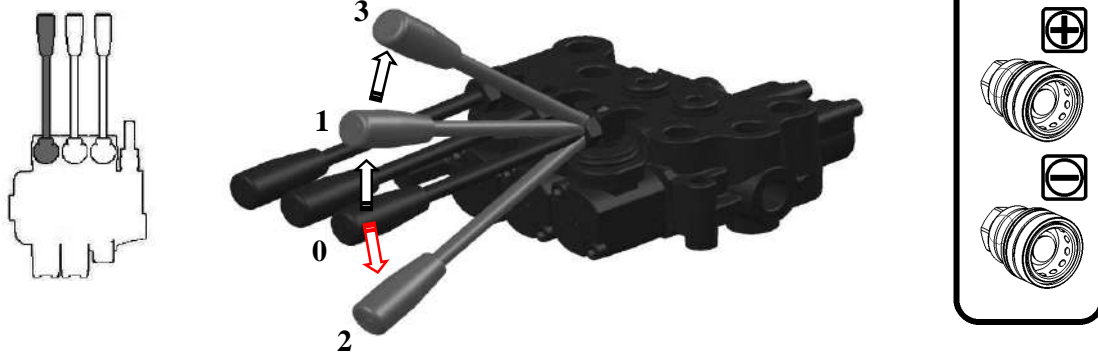

CONTROL OF HYDRAULICS THROUGH QUICK COUPLING (DOUBLE)

Control levers F and G

Control lever redirects oil from pressure circuit through two-way functioning 6/3-directional control valve through hydraulic output or quick coupling, to control implement external hydraulic implements with two-way functioning hydraulic cylinder.

Operation:

Operation is the same as with control lever E, when levers, regardless of position (1 or 2), always return to neutral position, when released. The difference is that the valves do not have a blocking device (DETENT).

Control levers F and G

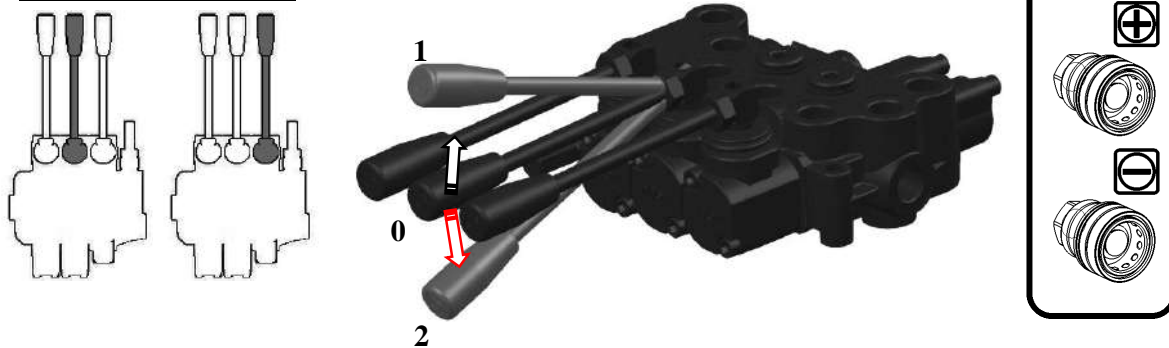

4.7.6 CONNECTION SHAFT OPERATION

Functions, which are installed on the tractor as standard, e.g. start of connection shaft, rotation of connection shaft according to operation mode, shut-off of connection shaft, start choke for soft start – PTO), are described in chapter "START OF CONNECTION SHAFT (PTO)".

Additional function of premium hydraulics is soft start with activation by switch (description below).

SOFT START (PTO)

The tractor has an option of soft start also with a switch on the dashboard. In case of first connection, according to weight of implement (force of rotation start), choke must be set first. Start the engine and:

- Press and hold switch for soft start (PTO) (1), choke must be closed;
- Activate switch of connection shaft (PTO) (2);
- Slowly start to open choke, until connection shaft starts rotating;
- Setting is complete, if you are using the same implement, it is not necessary to perform this procedure at each connection. Otherwise, repeat the procedure.

Soft start procedure of connection shaft with switch:

- Tractor must be shut down and handbrake engaged;
- Use the lever to select operation mode of connection shaft engine/gearbox (see chapter "DESCRIPTION OF CONTROL ELEMENTS FOR WORK – CONNECTION SHAFT");
- Start the engine;
- Press switch for soft start (PTO) (1);
- Activate switch of connection shaft (PTO) (2), (oil is supplied through choke to connection shaft);
- Hold the switch for soft start (PTO) (1), until the connection shaft rotates completely and then release it. Switch automatically returns to start position and deactivates solenoid valve for soft start (oil is supplied directly to connection shaft), connection shaft rotates.
- To shut it off, see chapter "SHUTTING OFF CONNECTION SHAFT".



4.7.7 OPERATION OF HYDRAULIC LIFT MECHANISM

Rear hydraulic lift mechanism is controlled by hydraulic cylinder, which can operate one- or two-way in connection with three-directional valve.

Operation of two-way hydraulic cylinder

Pressure, created by hydraulic oil, acts on piston in the cylinder alternately from both sides (depending on position of shift lever), which enable work travel of piston in both directions (lifting/lowering).

Operation of one-way hydraulic cylinder

Pressure, created by hydraulic oil, acts on piston in the cylinder from one side, which enables work travel in one direction (lifting), return travel (lowering) of cylinder is performed by external force – weight of the implement or with a spring.

	LIFTING	LOWERING
TWO-WAY FUNCTIONING HYDRAULIC CYLINDER		
ONE-WAY FUNCTIONING HYDRAULIC CYLINDER		

Rear hydraulic lift mechanism is controlled with control lever: if you move it in position (1), the mechanism begins rising, and in position (2) the mechanism begins lowering. For detailed description see chapter "OPERATION OF CONTROL ELEMENTS FOR HYDRAULICS".

Neutral (lever in position 0)

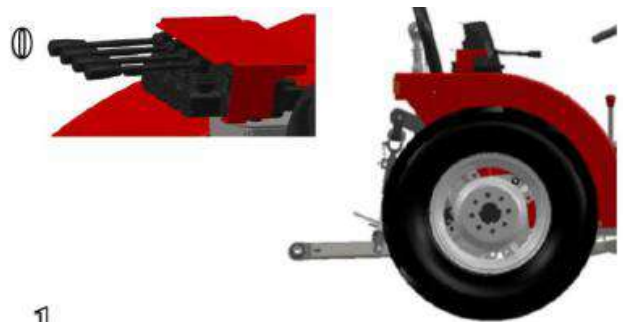

Lifting (lever in position 1)

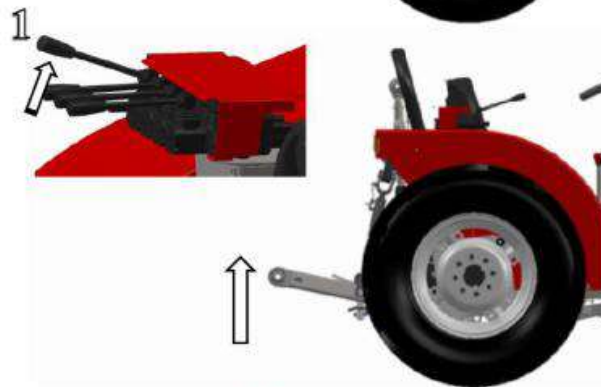

Lowering (lever in position 2)

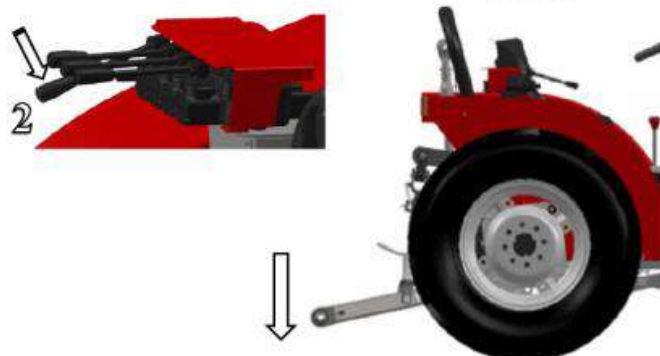

Float position (FLOAT – lever in position 3)

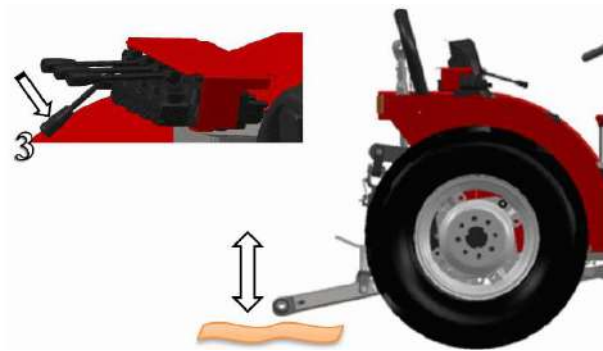

4.7.8 OPERATION OF 3-DIRECTIONAL VALVE

On rear hydraulic lift mechanism of the tractor, it is possible to transform two-way hydraulic cylinder into one-way with additional three-directional control valve, which is fitted to the right of the driver's seat.

- To transform to one-way functioning of hydraulic cylinder, move the lever on valve to position A.
- To transform to two-way functioning of hydraulic cylinder, move the lever on valve to position B.

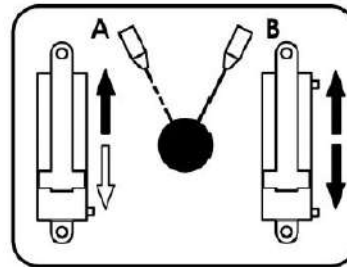

4.7.9 CHOKE OF REAR HYDRAULIC CYLINDERS

For different work requirement, the tractor also enables setting speed of movement of hydraulic cylinders on rear lift mechanisms. This is ensured by two chokes, installed on the right side below control elements. Chokes regulate amount of supplied oil into hydraulic cylinder. One choke is for setting speed of lifting, and the other choke for setting speed of lowering rear hydraulic lift mechanism.

Operation:

Lifting or lowering

- By turning the choke to the right (+), you are closing oil supply into hydraulic cylinders (choke – speed of cylinder movement is reduced);
- By turning the choke to the left (-), you are opening oil supply into hydraulic cylinders (speed of cylinder movement increases).

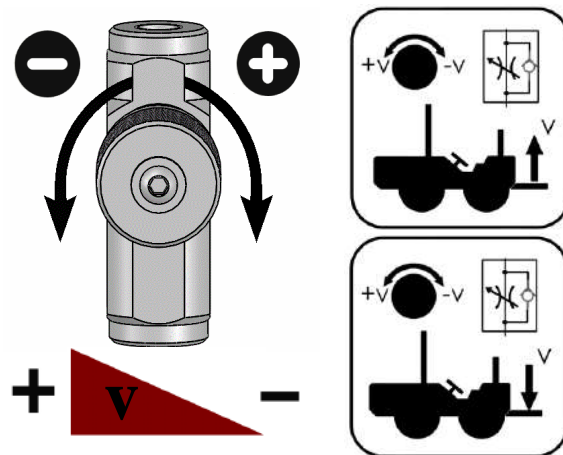

4.8 PREMIUM PLUS HYDRAULICS

Newer version of the tractor with Premium equipment has, beside existing hydraulics, additionally integrated system of floating hydraulics with support. This keeps the operation of control elements, connection shaft and chokes of rear hydraulic cylinders the same.

Besides existing Premium hydraulics, the following items are additionally installed:

1. **Valve for pressure preparation;**
2. **Battery**, intended for storing hydraulic energy;
3. **Control block**, intended for supporting weight of the implement, in which the previous three-directional valve for transformation of two-way cylinder into one way is also integrated.

4.8.1 HYDRAULIC SCHEME

LEGEND

1. Steering block
2. Hydraulic pump
3. Steering head
4. Four-directional valve
5. Cylinder housing
6. Control elements (four control levers)
7. Control elements (three control levers)
8. Filter
9. Connection shaft
10. Quick coupling (implement – two-way operation)
- 10.1 Quick coupling (implement – two-way operation)
- 10.2 Quick coupling (implement – two-way operation)
- 10.3 Quick coupling (implement – two-way operation)
11. Quick coupling (implement – two-way operation)
12. Choke (PTO)
13. Choke (rear hydraulic cylinder)
14. Steering mechanism cylinder
15. Rear part of transmission (gearbox)
16. Solenoid valve 3/2 (soft start PTO)
17. Valve 2/2
18. Hydraulic cylinder (lifting/lowering lower connection arm)
19. Rear hydraulic cylinder (option of one-way or two-way, lifting/lowering rear lift mechanism)
20. Steering block (regulation of support force of floating hydraulics and rear hydraulic cylinder in one- or two-way functioning)
21. Battery (storing hydraulic energy)
22. Valve for pressure preparation
23. Pressure gauge

HYDRAULIC SCHEME

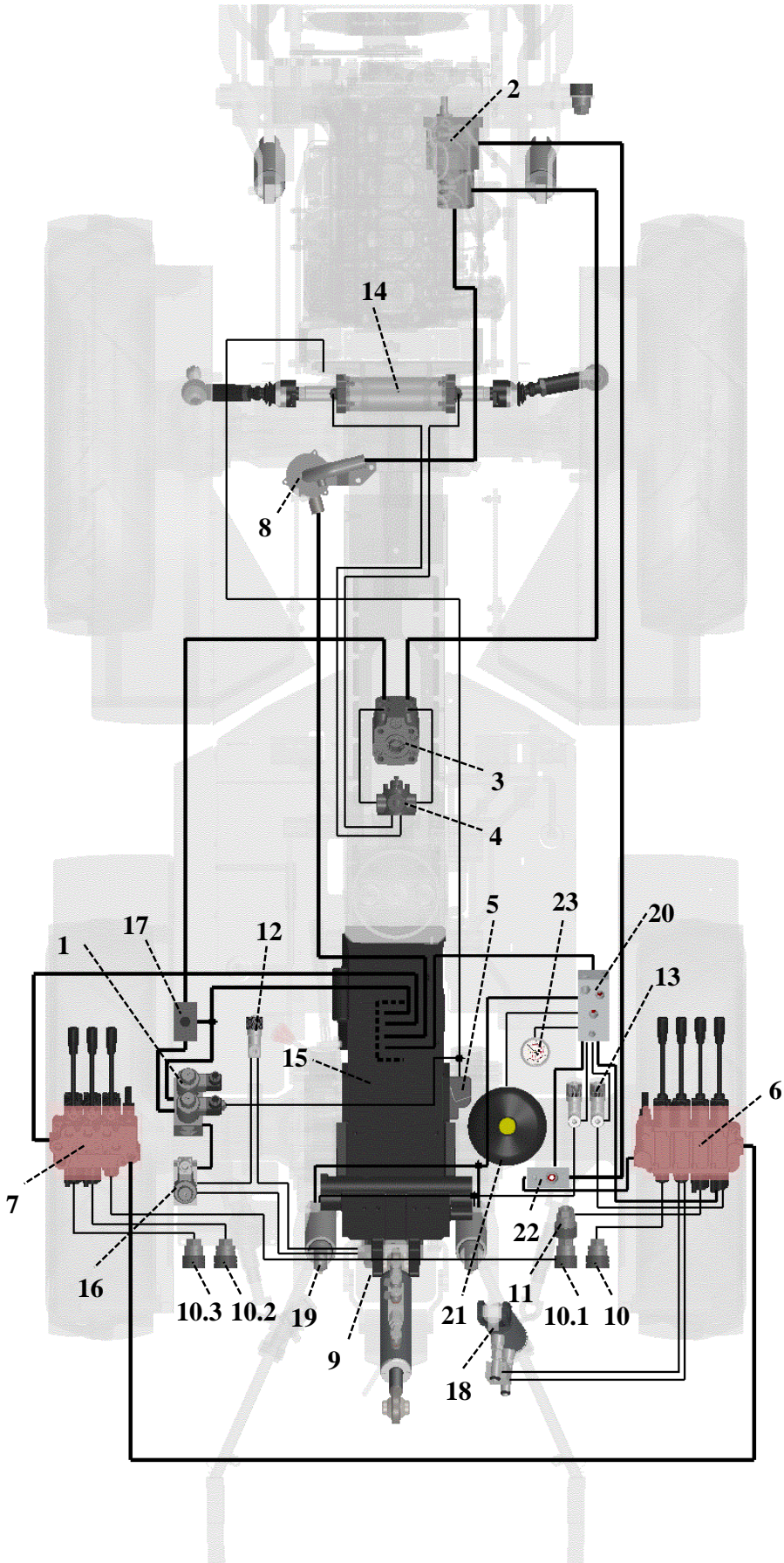

4.8.2 OPERATION OF FLOATING SYSTEM

To turn it on, first, press switch (1) on the dashboard, then shift control lever for control of rear hydraulic lift mechanism into position 3 (see chapter "PREMIUM HYDRAULICS – OPERATION OF CONTROL ELEMENTS"), and the floating system with support begins operating.

When you stop using the system, turn it off with the switch, you can do this also when the lever on control element is still in position 3. Then, the hydraulic lift mechanism remains in floating position, but without support (float).

You can turn off the system also by moving the lever into neutral position or by shutting the tractor off. Hydraulic battery automatically discharges, when you shut the engine off.

SYSTEM PRESSURE REGULATION

Set system pressure with adjustment knob (2). If you turn the knob clockwise, you increase the pressure, and if you turn it counter clockwise, you decrease the pressure. Pressure can also be set with switch turned off and tractor running.

When you connect implement for the first time or change existing implement with a new one, follow the procedure below:

- On/off switch (1) must be off;
- Unscrew safety nut (3);
- Decrease pressure to 0 bar (see pressure gauge) (4);
- Turn on floating system with support.



When the implement is connected, properly adjust pressure:

- Do this by rotating adjustment knob (2). It is recommended to adjust it according to weight of implement (see table below);
- Tighten safety nut, when you have completed adjustment.

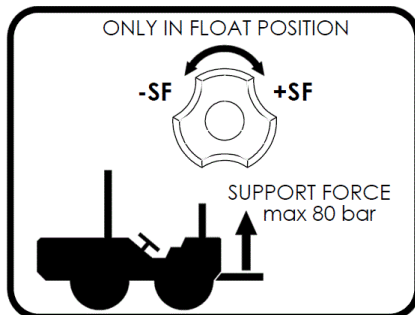
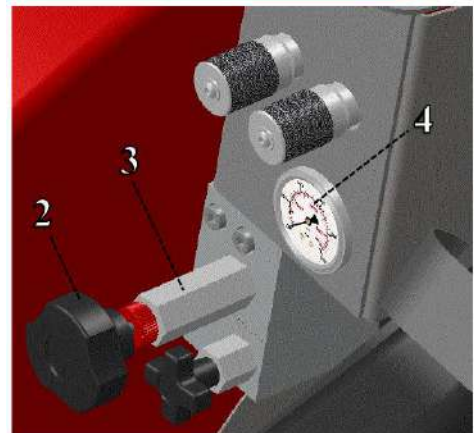

When working with the same implement, it is not necessary to perform procedure of pressure adjustment at every use.



WARNING: When connecting/disconnecting implement to/from tractor, switch must always be turned off and pressure on pressure gauge must show 0 bar. Otherwise, personal injury can occur due do uncontrolled lifting of hydraulic system!

4.8.3 CONTROL BLOCK OF HYDRAULIC SYSTEM

Control block, beside pressure regulation in floating system, also has the function of transforming two-way hydraulic cylinder into one-way, which replaces three-directional valve in existing Premium hydraulics.

- To transform into two-way functioning of hydraulic cylinder, turn adjustment knob (1) on block clockwise.
- To transform into one-way functioning of hydraulic cylinder, turn adjustment knob (1) on block counter clockwise.

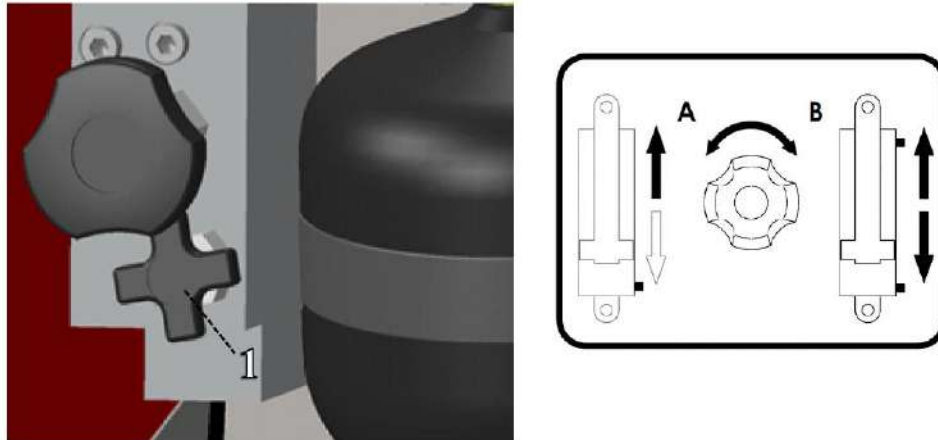

4.8.4 TABLE OF IMPLEMENT SUPPORT FORCE

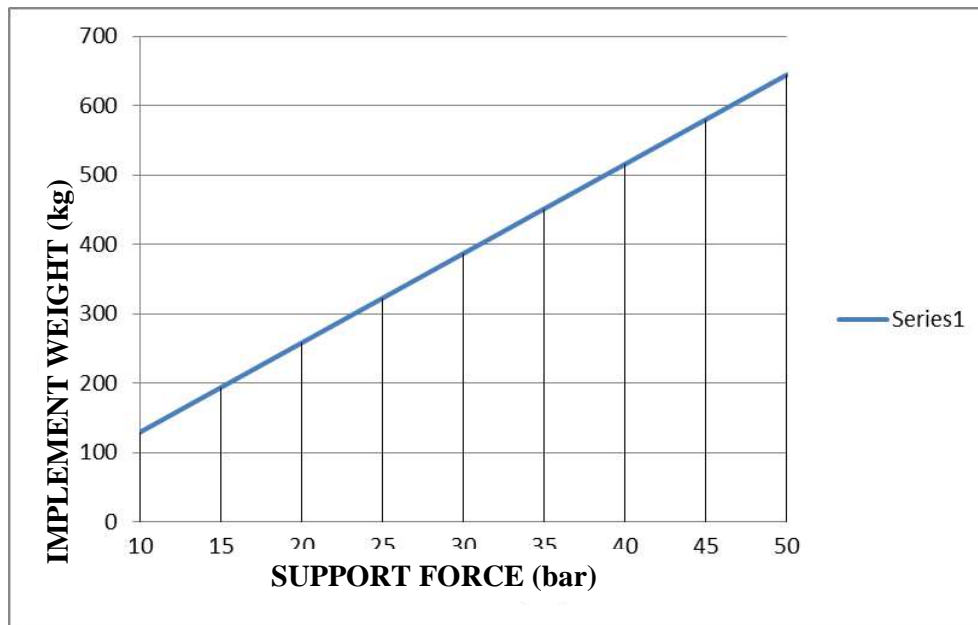

4.9 DESCRIPTION OF DEVICES FOR USING THE TRACTOR IN ROAD TRAFFIC

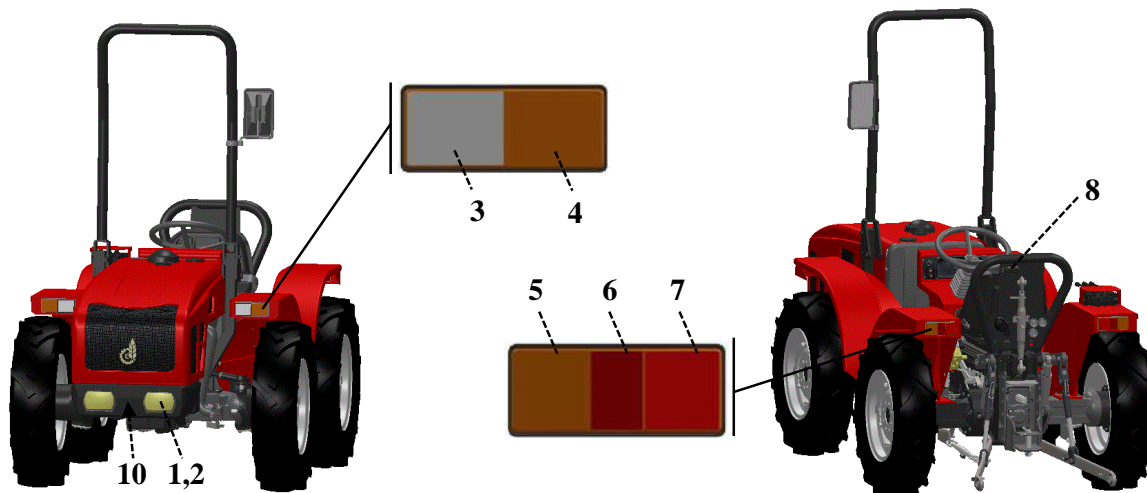

Headlights

1. Low beam
2. High beam

Side lights

3. Position lights
4. Front indicators

Rear lights

5. Rear indicators
6. Reflectors
7. Low beam and brake light
8. Plate light (always on with light switch on in any position)

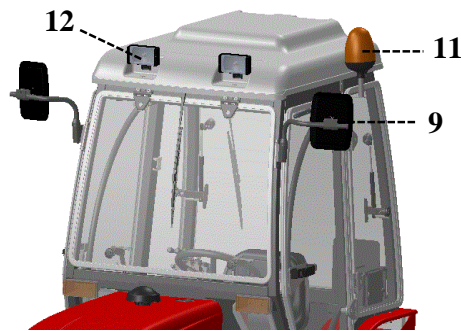

To turn lights on or off, see chapter "DESCRIPTION OF INSTRUMENTS AND CONTROL ELEMENTS".

9. Rear-view mirror
10. Horn
11. Rotation light (option)
12. Work lights

4.10 ELECTRICAL SYSTEM

4.10.1 BATTERY

Battery with rated voltage 12 V is an electrical power source for complete electrical supply of internal equipment of the tractor. Characteristics of the battery are described in chapter "TECHNICAL DATA".

Be careful that the battery is always clean and all contact connection well fastened and greased. We recommend that you lubricate all contacts, before fastening them, with lubricating grease, as this greatly reduces the risk of corrosion.

Launching or starting the engine must be performed according to instructions for start-up (see chapter "TRACTOR START-UP").

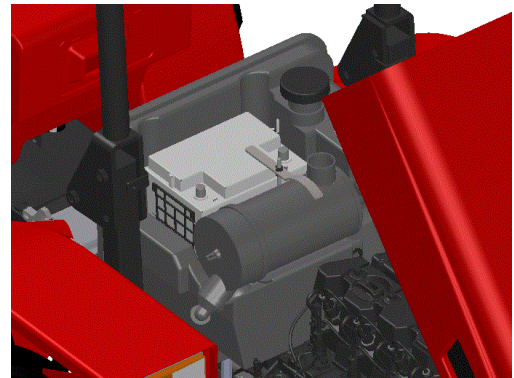

Access

To access the battery, raise the cover. The battery is on the tank, right at the beginning.

Occasionally check electrolyte level (amount must be between MIN and MAX mark), add distilled water, if required, if provided for by battery version. In the winter and at low external temperatures, when not using the tractor for a longer period of time, remove the battery from the tractor and store it in a warm area.

4.10.2 ELECTRIC STARTER

Electric starter is an electromotor, which is connected to engine flywheel through a sprocket. Electrical supply is provided directly from the battery. Characteristics of electric starter are described in chapter "TECHNICAL DATA".

Upon engine start-up, current with great power is used. Therefore, note the following, when using the starter:

- Starter can be engaged, without break, for maximum 10 seconds.
- If the engine does not start, wait at least 10 seconds before trying to start it again.
- If the engine does not start after several start-up attempts, stop start-up procedure and find the cause of the problem.

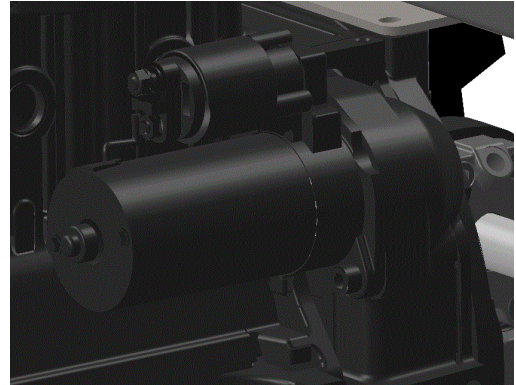
**4.10.3 ALTERNATOR**

Alternator ensures constant maintenance of required charge or voltage of battery, and it operates only when:

- It is properly mechanically fastened.
- It is properly connected to the battery.
- Electrical installation is not damaged.

Alternator operation control is performed by control light on the dashboard. If the alternator is working properly, control light is off during normal operation.

Characteristics of alternator are described in chapter "TECHNICAL DATA".

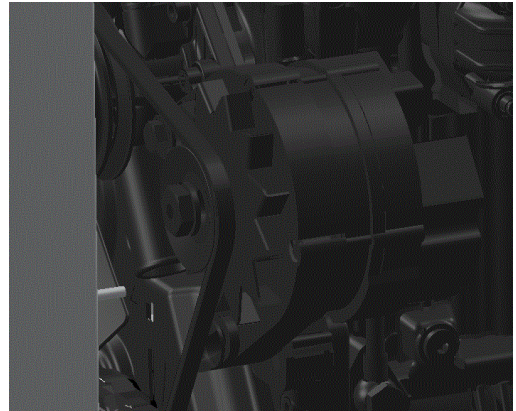
**4.10.4 FUSES**

Fuses are on the back of the dashboard.

If a fuse is blown, remove fuse-box cover and replace burnt fuse. If the fault repeats, have the electrical system inspected by an expert.

Before replacing burnt fuse:

- Move contact key to position.
- If possible, remedy the problem, which caused the fuse to blow.
- Replace burnt fuse.

